

Ningbo Amol Machinery Co., Ltd.
Jiangsu Amol Bearing Co., Ltd.
Ningbo Amol Intl. Trade Co., Ltd.



1. Types, design features, and characteristics

Cylindrical roller bearings can accommodate heavy radial loads due to the line contact formed between their rolling elements and raceways. These bearings are also suitable for high speed applications since the rollers are guided by either inner or outer ring ribs. Cylindrical roller bearings are separable, allowing them to be easily installed and disassembled even when interference fits are required. Among the various types of cylindrical roller bearings, E type and EA type have a high load capacity while maintaining standard boundary dimensions. HT type has a large axial load capacity, and HL type provides extended fatigue life in poor lubrication conditions. Multiple row bearing arrangements are also available. For extremely heavy load applications, the non-separable full complement SL type bearing offers special advantages. For SL type and fourrow cylindrical roller bearings, see section “C. Special application Bearings.” Table 1 shows the various types and characteristics of single row cylindrical roller bearings. Table 2 shows the characteristics of non-standard type cylindrical roller bearings.

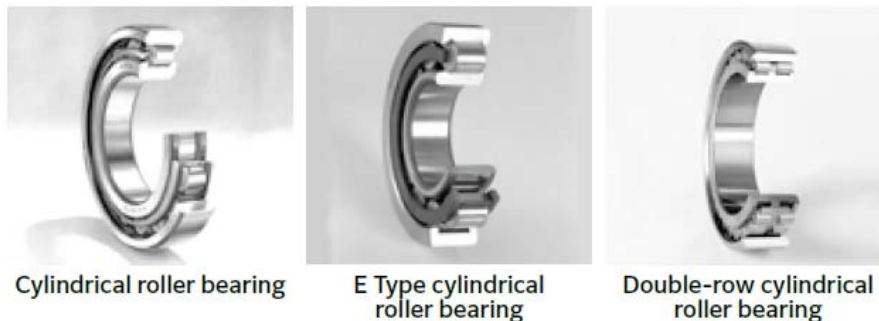

Table 1 Cylindrical roller bearing types and characteristics







Type code	Design	Characteristics
NU type N type	 <p>NU type</p> <p>N type</p>	<ul style="list-style-type: none"> • NU type outer rings have two ribs. The outer ring, roller, and cage assembly can be separated from the inner ring. • N type inner rings have two ribs. The inner ring, roller, and cage assembly can be separated from the outer ring. • Unable to accommodate any axial loading. • This is widely used as the floating side bearing in a fixed-float arrangement.
NJ type NF type	 <p>NJ type</p> <p>NF type</p>	<ul style="list-style-type: none"> • NJ type has two ribs on the outer ring, a single rib on the inner ring; NF type has a single rib on the outer ring, and two ribs on the inner ring. • Can receive single direction axial loads. • When there is no distinction between the fixed side and floating side bearing, these types can be used as a pair in close proximity.
NUP type NH type (NJ+HJ)	 <p>NUP type</p> <p>NH type</p>	<ul style="list-style-type: none"> • NUP type has a collar ring attached to the ribless side of the inner ring; NH type is NJ type with an L type collar ring attached. All of these collar rings are separable, and therefore it is necessary to fix the inner ring axially. • Can accommodate axial loads in either direction. • Widely used as the shaft's fixed-side bearing.

Table 2 Non-standard type cylindrical roller bearing characteristics

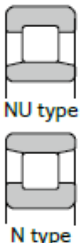
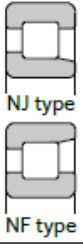
Designation	Characteristics
E type and EA type Cylindrical roller bearing	<ul style="list-style-type: none"> ● Boundary dimensions are the same as the standard type, but the diameter, length and number of the rollers have been increased, resulting in higher load capacity. ● Identified by the addition of "E" to the end of the basic roller number. ● Enables compact design due increased load rating. ● Rollers' inscribed circle diameter differs from the standard type rollers and therefore cannot be interchanged. ● EA type bearings are ULTAGE series¹⁾. <div data-bbox="456 751 1484 1062" style="text-align: center;">  <p style="text-align: center;"> E type Standard type NU2220E NU320 NU224E Cr=370kN Cr=330kN Cr=370kN E type bearing Standard type bearing E type bearing </p> </div> <p>Note: In the dimension tables, both E type and EA type are listed.</p>
Cylindrical roller bearing for axial loads (HT type)	<ul style="list-style-type: none"> ● Can accommodate larger axial loads than the standard type due to improved geometry of the rib roller end surface. ● Please consult WBW Engineering concerning necessary considerations, such as load, lubricant, and installation conditions.
Double-row cylindrical roller bearing	<ul style="list-style-type: none"> ● NN type and NNU type are available. ● Widely used for applications requiring thin-walled bearings, such the main shafts of machine tools, rolling machine rollers, and in printing equipment. ● Internal radial clearance is adjusted for the spindle of machine tools by pressing the tapered bore of the inner ring on a tapered shaft. <p>Remarks: For precision bearings for machine tools, see precision rolling bearings (CAT. No. 2260/E).</p>

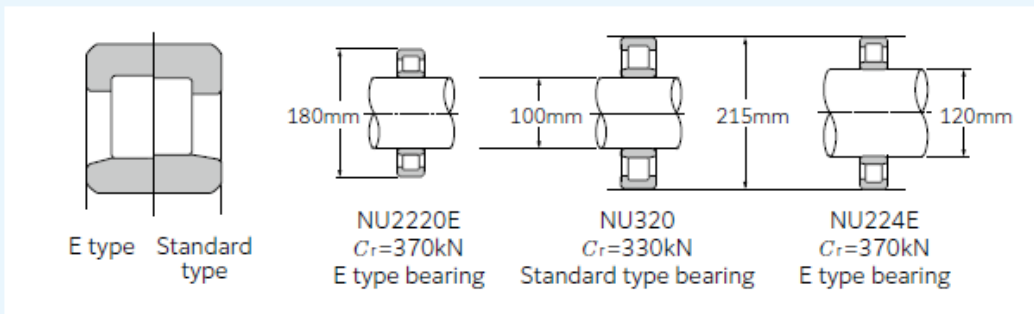
CAGES USED IN THE CYLINDRICAL ROLLER BEARINGS

Table 3 Standard cage types

Cage type	Resin cage	Pressed cage	Machined cage	
			Single type	Studded double type
Bearing series				
NU10	—	—	—	1005 to 10/500
NU2	—	208 to 230	232 to 240	244 to 264
NU2E	—	—	220E to 240E	—
NU2EA	204EA to 219EA	—	—	—
NU22	—	2208 to 2230	2232 to 2240	2244 to 2264
NU22E	—	—	2219E to 2240E	—
NU22EA	2204EA to 2218EA	—	—	—
NU3	—	308 to 324	326 to 330	332 to 356
NU3E	—	—	316E to 332E	—
NU3EA	304EA to 315EA	—	—	—
NU23	—	2308 to 2320	2322 to 2330	2332 to 2356
NU23E	—	—	2316E to 2332E	—
NU23EA	2304EA to 2315EA	—	—	—
NU4	—	405 to 416	—	—

Edge loading due to misalignment under general load conditions should be avoided to prevent premature bearing failure, The maximum allowable misalignment based on bearing series can be found below. The values apply when the bearings are to be used as the floating side of NU and N types. For NJ, NUP, and NH types that are to be used for the fixed side.

Table 4 Combination type

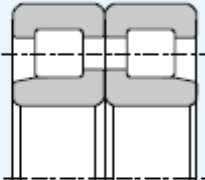
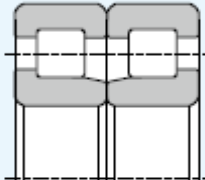
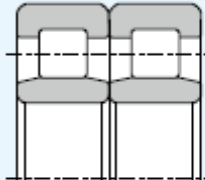
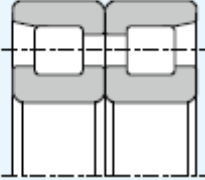
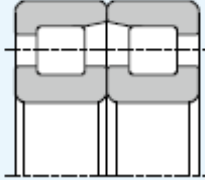
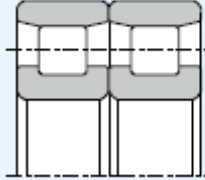
Back-to-back arrangement (DB)	Face-to-face arrangement (DF)	Symmetrical parts arrangement (D2)
 NJ type	 NJ type	 NU type
 NF type	 NF type	 N type

How we name cylindrical roller bearings:

Cylindrical roller bearing

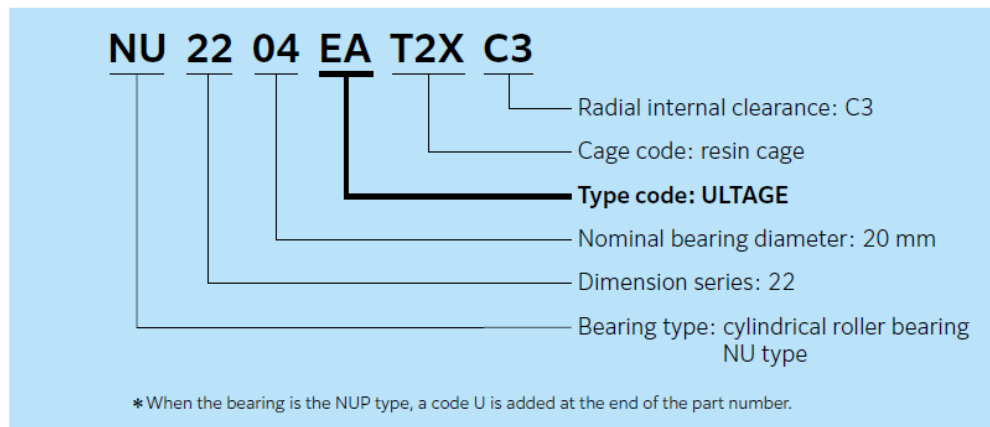

Table 8.12 Interchangeable radial internal clearance for cylindrical roller bearing
 (cylindrical bore)

Unit: μm

Nominal bearing bore diameter <i>d</i> mm		C2		CN		C3		C4		C5	
		Over	Incl.	Min.	Max.	Min.	Max.	Min.	Max.	Min.	Max.
—	10	0	25	20	45	35	60	50	75	—	—
10	24	0	25	20	45	35	60	50	75	65	90
24	30	0	25	20	45	35	60	50	75	70	95
30	40	5	30	25	50	45	70	60	85	80	105
40	50	5	35	30	60	50	80	70	100	95	125
50	65	10	40	40	70	60	90	80	110	110	140
65	80	10	45	40	75	65	100	90	125	130	165
80	100	15	50	50	85	75	110	105	140	155	190
100	120	15	55	50	90	85	125	125	165	180	220
120	140	15	60	60	105	100	145	145	190	200	245
140	160	20	70	70	120	115	165	165	215	225	275
160	180	25	75	75	125	120	170	170	220	250	300
180	200	35	90	90	145	140	195	195	250	275	330
200	225	45	105	105	165	160	220	220	280	305	365
225	250	45	110	110	175	170	235	235	300	330	395
250	280	55	125	125	195	190	260	260	330	370	440
280	315	55	130	130	205	200	275	275	350	410	485
315	355	65	145	145	225	225	305	305	385	455	535
355	400	100	190	190	280	280	370	370	460	510	600
400	450	110	210	210	310	310	410	410	510	565	665
450	500	110	220	220	330	330	440	440	550	625	735

Table 8.13 Non-interchangeable radial internal clearance for cylindrical roller bearing

Nominal bearing bore diameter <i>d</i> mm		Cylindrical bore bearing											
		C1NA		C2NA		NA ¹⁾		C3NA		C4NA		C5NA	
Over	Incl.	Min.	Max.	Min.	Max.	Min.	Max.	Min.	Max.	Min.	Max.	Min.	Max.
—	10	5	10	10	20	20	30	35	45	45	55	—	—
10	18	5	10	10	20	20	30	35	45	45	55	65	75
18	24	5	10	10	20	20	30	35	45	45	55	65	75
24	30	5	10	10	25	25	35	40	50	50	60	70	80
30	40	5	12	12	25	25	40	45	55	55	70	80	95
40	50	5	15	15	30	30	45	50	65	65	80	95	110
50	65	5	15	15	35	35	50	55	75	75	90	110	130
65	80	10	20	20	40	40	60	70	90	90	110	130	150
80	100	10	25	25	45	45	70	80	105	105	125	155	180
100	120	10	25	25	50	50	80	95	120	120	145	180	205
120	140	15	30	30	60	60	90	105	135	135	160	200	230
140	160	15	35	35	65	65	100	115	150	150	180	225	260
160	180	15	35	35	75	75	110	125	165	165	200	250	285
180	200	20	40	40	80	80	120	140	180	180	220	275	315
200	225	20	45	45	90	90	135	155	200	200	240	305	350
225	250	25	50	50	100	100	150	170	215	215	265	330	380
250	280	25	55	55	110	110	165	185	240	240	295	370	420
280	315	30	60	60	120	120	180	205	265	265	325	410	470
315	355	30	65	65	135	135	200	225	295	295	360	455	520
355	400	35	75	75	150	150	225	255	330	330	405	510	585
400	450	45	85	85	170	170	255	285	370	370	455	565	650
450	500	50	95	95	190	190	285	315	410	410	505	625	720

1) For bearings with normal clearance, only NA is added to bearing numbers. Example: NU310NA

Bearing damage	Damaged parts	Causes															
		Handling		Bearing periphery			Lubrication		Load			Speed		Bearing selection			
		Poor storage condition/vibration during transportation	Improper handling/installation	Insufficient accuracy of shaft/housing	Infiltration of bearing by foreign matter (insufficient sealing performance)	Temperature (heat effect)	Lubricant (insufficient/inproper quality)	Lubrication method (insufficient)	Load/preload	Excessively large impact load	Excessively large moment	Excessively small load	High speed/rapid acceleration and deceleration	Large vibration	Swinging/vibration/standstill	Excessively large/small clearance	Excessively large/small interference
Flaking (separation)	Raceway surface/rolling element surface		○	○	○	○	○	○	○	○						○	
Seizure	Raceway/rolling element/cage		○			○	○	○	○	○		○				○	
Cracks/chips	Raceway/rolling element		○	○				○	○								○
Cage damage	Rivets break or become loose		○		○		○	○	○	○		○	○				
Rolling path skewing	Raceway surface		○	○												○	
Smearing/scuffing	Raceway surface/rolling element surface/rib surface/roller end surface		○		○		○	○	○		○						
Rust/corrosion	Rust on a part of or the entire surface of the rolling element pitch	○	○		○		○	○									
Fretting	Red rust on fitting surface		○						○			○					
	Brinelling indentations form on the raceway of the rolling element pitch	○					○	○						○			○
Wear	Raceway surface/rolling element surface/rib surface/roller end surface		○		○		○	○									
Electrolytic corrosion	Pits form on the raceway. The pits gradually grow into ripples.		○														
Dents and scratches	Raceway surface/rolling element surface		○		○				○	○							
Creeping	Fitting surface		○	○		○			○								○
Speckles and discoloration	Raceway surface/rolling element surface				○		○	○									
Peeling	Raceway surface/rolling element surface				○		○	○									

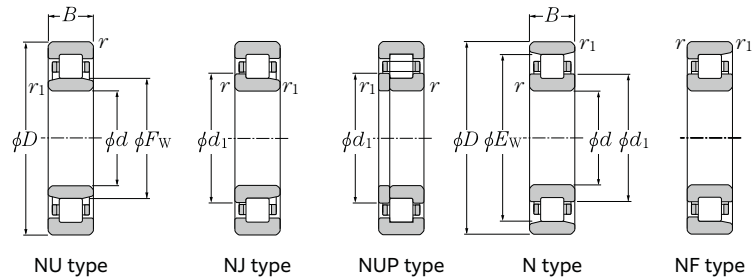

d 20 ~ 45mm

d	Boundary dimensions				Basic load rating		Fatigue load limit kN C _u	Allowable speed ²⁾		Bearing number ^{3) 4) 5)}			
	D	B	r _{s min¹⁾}	r _{1s min¹⁾}	dynamic kN C _r	static kN C _{0r}		Grease lubrication	Oil lubrication	NU type	NJ type	NUP type	N type
20	47	14	1	0.6	32.5	24.7	3.00	15 000	21 600	*NU204EA	NJ	NUP	N
	47	18	1	0.6	38.5	31.0	3.75	14 000	19 200	*NU2204EA	NJ	NUP	N
	52	15	1.1	0.6	37.5	26.9	3.25	13 000	18 000	*NU304EA	NJ	NUP	N
	52	21	1.1	0.6	49.5	39.0	4.75	12 000	16 800	*NU2304EA	NJ	NUP	N
25	47	12	0.6	0.3	16.7	14.1	1.72	16 000	19 000	NU1005	NJ	NUP	N
	52	15	1	0.6	34.5	27.7	3.40	13 000	18 000	*NU205EA	NJ	NUP	N
	52	18	1	0.6	41.5	34.5	4.25	11 000	15 600	*NU2205EA	NJ	NUP	N
	62	17	1.1	1.1	49.0	37.5	4.55	11 000	15 600	*NU305EA	NJ	NUP	N
	62	24	1.1	1.1	67.5	56.0	6.85	9 700	13 200	*NU2305EA	NJ	NUP	N
80	21	1.5	1.5	51.5	40.0	4.85	8 500	10 000	NU405	NJ	NUP	N	
30	55	13	1	0.6	21.8	19.6	2.39	14 000	16 000	NU1006	NJ	NUP	N
	62	16	1	0.6	46.0	37.5	4.55	11 000	15 600	*NU206EA	NJ	NUP	N
	62	20	1	0.6	58.0	50.0	6.10	9 700	13 200	*NU2206EA	NJ	NUP	N
	72	19	1.1	1.1	63.0	50.0	6.15	9 300	13 200	*NU306EA	NJ	NUP	N
	72	27	1.1	1.1	88.0	77.5	9.45	8 300	11 600	*NU2306EA	NJ	NUP	N
90	23	1.5	1.5	69.5	55.0	6.70	7 300	8 500	NU406	NJ	NUP	N	
35	62	14	1	0.6	25.1	23.2	2.82	12 000	15 000	NU1007	NJ	NUP	N
	72	17	1.1	0.6	59.5	50.0	6.10	9 500	13 200	*NU207EA	NJ	NUP	N
	72	23	1.1	0.6	73.0	65.5	7.95	8 500	12 000	*NU2207EA	NJ	NUP	N
	80	21	1.5	1.1	83.5	71.0	8.65	8 100	11 500	*NU307EA	NJ	NUP	N
	80	31	1.5	1.1	117	109	13.3	7 200	10 200	*NU2307EA	NJ	NUP	N
100	25	1.5	1.5	83.5	69.0	8.40	6 400	7 500	NU407	NJ	NUP	N	
40	68	15	1	0.6	30.5	29.0	3.55	11 000	13 000	NU1008	NJ	NUP	N
	80	18	1.1	1.1	48.5	43.0	5.25	9 400	11 000	*NU208	NJ	NUP	N
	80	18	1.1	1.1	66.0	55.5	6.75	8 500	12 000	*NU208EA	NJ	NUP	N
	80	23	1.1	1.1	64.5	62.0	7.55	8 500	10 000	*NU2208	NJ	NUP	N
	80	23	1.1	1.1	85.5	77.5	9.45	7 600	10 700	*NU2208EA	NJ	NUP	N
	90	23	1.5	1.5	65.0	57.0	6.95	8 000	9 400	*NU308	NJ	NUP	N
	90	23	1.5	1.5	98.5	81.5	9.95	7 200	10 200	*NU308EA	NJ	NUP	N
	90	33	1.5	1.5	91.5	88.0	10.7	7 000	8 200	*NU2308	NJ	NUP	N
	90	33	1.5	1.5	135	122	14.9	6 400	9 000	*NU2308EA	NJ	NUP	N
110	27	2	2	106	89.0	10.9	5 700	6 700	NU408	NJ	NUP	N	
45	75	16	1	0.6	34.5	34.0	4.10	9 900	12 000	NU1009	NJ	NUP	N

1) Smallest allowable dimension for chamfer dimension r or r₁.
 2) This value is for machined cages; when pressed cages are used, 80% of this value is acceptable.
 3) Bearing numbers marked "*" designate ULTAGE series bearings. 4) Bearing marked "*" are going to be integrated with ULTAGE Series.

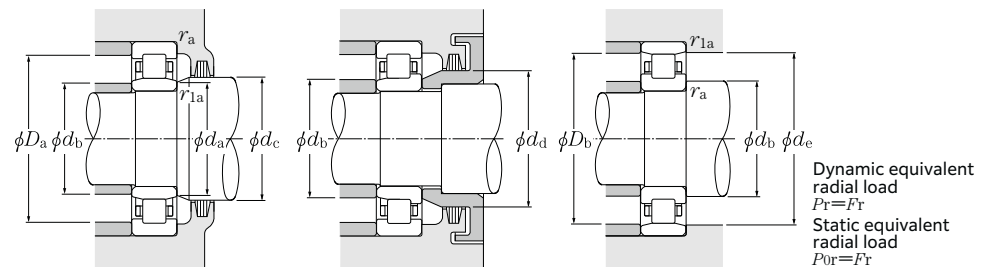

Dynamic equivalent radial load
P_r = F_r
Static equivalent radial load
P_{0r} = F_r

NF type	Dimension				Installation-related dimensions										Mass	
	F _w	E _w	d ₁	d _a Min.	d _e Min.	d _b Max.	d _c Min.	d _d Min.	d _a Max.	D _b Max.	D _b Min. ⁶⁾	r _{as} Max.	r _{1as} Max.	NU type (approx.)	N type (approx.)	
NF	26.5	41.5	29.5	24	25	26	29	32	42	42	42.5	1	0.6	0.115	0.11	
NF	26.5	41.5	29.5	24	25	26	29	32	42	42	42.5	1	0.6	0.146	0.144	
NF	27.5	45.5	31.1	24	26.5	27	30	33	45.5	45.5	46.5	1	0.6	0.176	0.147	
NF	27.5	45.5	31.1	24	26.5	27	30	33	45.5	45.5	46.5	1	0.6	0.242	0.212	
—	30.5	41.5	32.7	27	29	30	32	33	43	45	42.5	0.6	0.3	0.092	0.091	
NF	31.5	46.5	34.5	29	30	31	34	37	47	47	47.5	1	0.6	0.151	0.13	
NF	31.5	46.5	34.5	29	30	31	34	37	47	47	47.5	1	0.6	0.186	0.163	
NF	34	54	38	31.5	31.5	33	37	40	55.5	55.5	55	1	1	0.275	0.242	
NF	34	54	38	31.5	31.5	33	37	40	55.5	55.5	55	1	1	0.386	0.345	
NF	38.8	62.8	43.6	33	33	38	41	46	72	72	64	1.5	1.5	0.55	0.536	
—	36.5	48.5	38.9	34	35	35	38	39.5	50	51	49.5	1	0.6	0.13	0.128	
NF	37.5	55.5	41.1	34	35	37	40	44	57	57	56.5	1	0.6	0.226	0.205	
NF	37.5	55.5	41.1	34	35	37	40	44	57	57	56.5	1	0.6	0.297	0.259	
NF	40.5	62.5	44.9	36.5	36.5	40	44	48	65.5	65.5	64	1	1	0.398	0.353	
NF	40.5	62.5	44.9	36.5	36.5	40	44	48	65.5	65.5	64	1	1	0.58	0.526	
NF	45	73	50.5	38	38	44	47	52	82	82	74	1.5	1.5	0.751	0.732	
—	42	55	44.6	39	40	41	44	45	57	58	56	1	0.6	0.179	0.176	
NF	44	64	48	39	41.5	43	46	50	65.5	65.5	65.5	1	0.6	0.327	0.294	
NF	44	64	48	39	41.5	43	46	50	65.5	65.5	65.5	1	0.6	0.455	0.405	
NF	46.2	70.2	51	41.5	43	45	48	53	72	72	71.5	1.5	1	0.545	0.483	
NF	46.2	70.2	51	41.5	43	45	48	53	72	72	71.5	1.5	1	0.78	0.737	
NF	53	83	59	43	43	52	55	61	92	92	84	1.5	1.5	0.99	0.965	
—	47	61	49.8	44	45	46	49	50.5	63	64	62	1	0.6	0.22	0.217	
NF	50	70	54.2	46.5	46.5	49	52	56	73.5	73.5	72	1	1	0.378	0.37	
NF	49.5	71.5	53.9	46.5	46.5	49	52	56	73.5	73.5	72.5	1	1	0.426	0.365	
—	50	70	54.2	46.5	46.5	49	52	56	73.5	73.5	72	1	1	0.49	0.48	
NF	49.5	71.5	53.9	46.5	46.5	49	52	56	73.5	73.5	72.5	1	1	0.552	0.491	
NF	53.5	77.5	58.4	48	48	51	55	60	82	82	80	1.5	1.5	0.658	0.643	
NF	52	80	57.6	48	48	51	55	60	82	82	81.5	1.5	1.5	0.754	0.658	
—	53.5	77.5	58.4	48	48	51	55	60	82	82	80	1.5	1.5	0.951	0.932	
NF	52	80	57.6	48	48	51	55	60	82	82	81.5	1.5	1.5	1.06	0.952	
NF	58	92	64.8	49	49	57	60	67	101	101	93	2	2	1.3	1.27	
—	52.5	67.5	55.5	49	50	52	54	56	70	71	68.5	1	0.6	0.28	0.276	

5) Bearing numbers having no standard form are switched to type E or ULTAGE Series.
 6) Does not apply to the sides of the outer ring rib of type NF bearings.

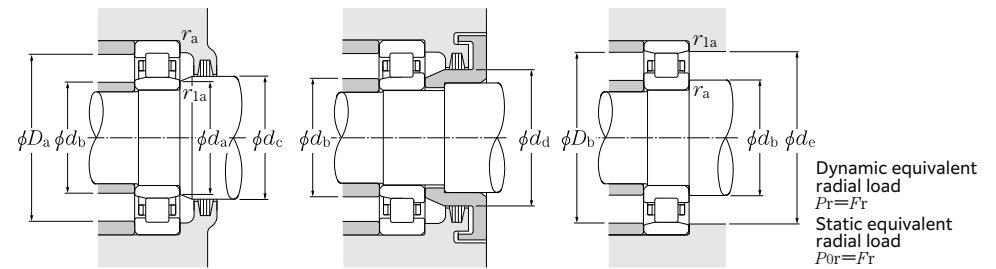
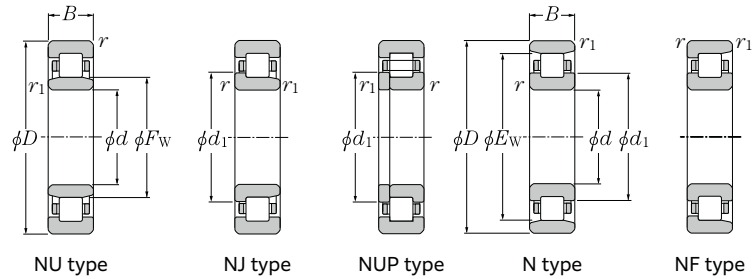

d 45 ~ 60mm

d	Boundary dimensions				Basic load rating		Fatigue load limit kN C _u	Allowable speed ²⁾		Bearing number ^{3) 4)}			
	D	B	r _{s min¹⁾}	r _{1s min¹⁾}	C _r	C _{0r}		Grease lubrication	Oil lubrication	min ⁻¹	min ⁻¹	NU type	NJ type
45	85	19	1.1	1.1	51.0	47.0	5.70	8 400	9 900	**NU209	NJ	NUP	N
	85	19	1.1	1.1	74.5	66.5	8.10	7 600	10 800	**NU209EA	NJ	NUP	N
	85	23	1.1	1.1	68.0	68.0	8.25	7 600	9 000	**NU2209	NJ	NUP	N
	85	23	1.1	1.1	90.0	84.5	10.3	6 800	9 600	**NU2209EA	NJ	NUP	N
	100	25	1.5	1.5	82.0	71.0	8.65	7 200	8 400	**NU309	NJ	NUP	N
	100	25	1.5	1.5	115	98.5	12.0	6 500	9 100	**NU309EA	NJ	NUP	N
	100	36	1.5	1.5	110	104	12.7	6 300	7 400	**NU2309	NJ	NUP	N
	100	36	1.5	1.5	162	153	18.7	5 700	8 200	**NU2309EA	NJ	NUP	N
	120	29	2	2	119	102	12.4	5 100	6 000	NU409	NJ	NUP	N
50	80	16	1	0.6	35.5	36.0	4.40	8 900	11 000	NU1010	NJ	NUP	N
	90	20	1.1	1.1	53.5	51.0	6.20	7 600	9 000	**NU210	NJ	NUP	N
	90	20	1.1	1.1	81.5	76.5	9.30	6 900	9 700	**NU210EA	NJ	NUP	N
	90	23	1.1	1.1	71.0	73.5	9.00	6 900	8 100	**NU2210	NJ	NUP	N
	90	23	1.1	1.1	98.5	97.0	11.9	6 200	8 800	**NU2210EA	NJ	NUP	N
	110	27	2	2	96.5	86.0	10.5	6 500	7 700	**NU310	NJ	NUP	N
	110	27	2	2	130	113	13.8	5 900	8 300	**NU310EA	NJ	NUP	N
	110	40	2	2	134	131	16.0	5 700	6 700	**NU2310	NJ	NUP	N
	110	40	2	2	192	187	22.7	5 200	7 300	**NU2310EA	NJ	NUP	N
130	31	2.1	2.1	143	124	15.1	4 700	5 500	NU410	NJ	NUP	N	
55	90	18	1.1	1	42.0	44.0	5.35	8 200	9 700	NU1011	NJ	NUP	N
	100	21	1.5	1.1	64.5	62.5	7.60	6 900	8 200	**NU211	NJ	NUP	N
	100	21	1.5	1.1	102	98.5	12.0	6 300	8 900	**NU211EA	NJ	NUP	N
	100	25	1.5	1.1	83.5	87.0	10.6	6 300	7 400	**NU2211	NJ	NUP	N
	100	25	1.5	1.1	120	122	14.8	5 600	7 900	**NU2211EA	NJ	NUP	N
	120	29	2	2	123	111	13.6	5 900	7 000	**NU311	NJ	NUP	N
	120	29	2	2	162	143	17.4	5 300	7 600	**NU311EA	NJ	NUP	N
	120	43	2	2	164	162	19.8	5 200	6 100	**NU2311	NJ	NUP	N
	120	43	2	2	238	233	28.4	4 700	6 700	**NU2311EA	NJ	NUP	N
140	33	2.1	2.1	154	138	16.9	4 300	5 000	NU411	NJ	NUP	N	
60	95	18	1.1	1	44.5	48.5	5.95	7 500	8 800	NU1012	NJ	NUP	N
	110	22	1.5	1.5	76.0	75.0	9.15	6 400	7 600	**NU212	NJ	NUP	N
	110	22	1.5	1.5	115	107	13.1	5 800	8 200	**NU212EA	NJ	NUP	N
	110	28	1.5	1.5	107	116	14.1	5 800	6 800	**NU2212	NJ	NUP	N
	110	28	1.5	1.5	155	157	19.1	5 200	7 300	**NU2212EA	NJ	NUP	N

1) Smallest allowable dimension for chamfer dimension r or r₁.
 2) This value is for machined cages; when pressed cages are used, 80% of this value is acceptable.
 3) Bearing numbers marked "*" designate ULTAGE series bearings. 4) Bearing marked "**" are going to be integrated with ULTAGE Series.

NF type	Dimension							Installation-related dimensions							Mass	
	F _w	E _w	d ₁	d _a	d _e	d _b	d _c	d _d	D _a	D _b	r _{as}	r _{1as}	NU type	N type		
NF	55	75	59	51.5	51.5	54	57	61	78.5	78.5	77	1	1	0.432	0.423	
NF	54.5	76.5	58.9	51.5	51.5	54	57	61	78.5	78.5	77.5	1	1	0.495	0.423	
—	55	75	59	51.5	51.5	54	57	61	78.5	78.5	77	1	1	0.53	0.52	
NF	54.5	76.5	58.9	51.5	51.5	54	57	61	78.5	78.5	77.5	1	1	0.6	0.533	
NF	58.5	86.5	64	53	53	57	60	66	92	92	89	1.5	1.5	0.877	0.857	
NF	58.5	88.5	64.5	53	53	57	60	66	92	92	90.5	1.5	1.5	0.996	0.865	
—	58.5	86.5	64	53	53	57	60	66	92	92	89	1.5	1.5	1.27	1.24	
NF	58.5	88.5	64.5	53	53	57	60	66	92	92	90.5	1.5	1.5	1.41	1.3	
NF	64.5	100.5	71.8	54	54	63	66	74	111	111	102	2	2	1.62	1.58	
—	57.5	72.5	60.5	54	55	57	59	61	75	76	73.5	1	0.6	0.295	0.291	
NF	60.4	80.4	64.6	56.5	56.5	58	62	67	83.5	83.5	83	1	1	0.47	0.46	
NF	59.5	81.5	63.9	56.5	56.5	58	62	67	83.5	83.5	82.5	1	1	0.503	0.47	
—	60.4	80.4	64.6	56.5	56.5	58	62	67	83.5	83.5	83	1	1	0.571	0.56	
NF	59.5	81.5	63.9	56.5	56.5	58	62	67	83.5	83.5	82.5	1	1	0.587	—	
NF	65	95	71	59	59	63	67	73	101	101	98	2	2	1.14	1.11	
NF	65	97	71.4	59	59	63	67	73	101	101	99	2	2	1.3	1.12	
—	65	95	71	59	59	63	67	73	101	101	98	2	2	1.7	1.67	
NF	65	97	71.4	59	59	63	67	73	101	101	99	2	2	1.9	1.75	
NF	70.8	110.8	78.8	61	61	69	73	81	119	119	112	2	2	2.02	1.97	
—	64.5	80.5	67.7	60	61.5	63	66	68.5	83.5	85	81.5	1	1	0.442	0.435	
NF	66.5	88.5	70.8	61.5	63	65	68	73	92	93.5	91	1.5	1	0.638	0.626	
NF	66	90	70.8	61.5	63	65	68	73	92	92	91	1.5	1	0.675	0.635	
—	66.5	88.5	70.8	61.5	63	65	68	73	92	93.5	91	1.5	1	0.773	0.758	
NF	66	90	70.8	61.5	63	65	68	73	92	92	91	1.5	1	0.807	—	
NF	70.5	104.5	77.2	64	64	69	72	80	111	111	107	2	2	1.45	1.42	
NF	70.5	106.5	77.7	64	64	69	72	80	111	111	108.5	2	2	1.65	1.43	
—	70.5	104.5	77.2	64	64	69	72	80	111	111	107	2	2	2.17	2.13	
NF	70.5	106.5	77.7	64	64	69	72	80	111	111	108.5	2	2	2.37	2.23	
NF	77.2	117.2	85.2	66	66	76	79	87	129	129	119	2	2	2.48	2.42	
—	69.5	85.5	72.7	65	66.5	68	71	73.5	88.5	90	86.5	1	1	0.474	0.467	
NF	73.5	97.5	78.4	68	68	71	75	80	102	102	100	1.5	1.5	0.818	0.802	
NF	72	100	77.6	68	68	71	75	80	102	102	101	1.5	1.5	0.923	0.798	
—	73.5	97.5	78.4	68	68	71	75	80	102	102	100	1.5	1.5	1.06	1.04	
NF	72	100	77.6	68	68	71	75	80	102	102	101	1.5	1.5	1.21	1.08	

5) Does not apply to the sides of the outer ring rib of type NF bearings.

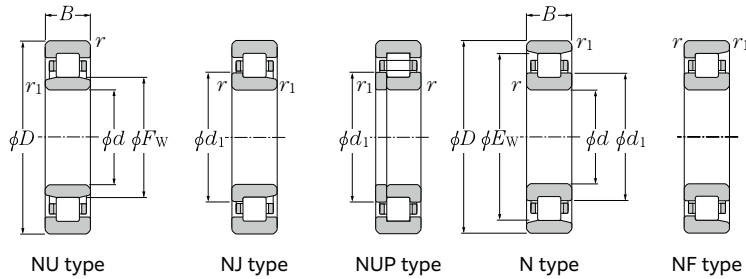

d 60 ~ 75mm

d	Boundary dimensions				Basic load rating		Fatigue load limit kN C _u	Allowable speed ²⁾		Bearing number ^{3) 4)}			
	D	B	r _{s min} ¹⁾	r _{1s min} ¹⁾	C _r	C _{0r}		Grease lubrication	Oil lubrication	NU type	NJ type	NUP type	N type
60	130	31	2.1	2.1	137	126	15.4	5 500	6 500	**NU312	NJ	NUP	N
	130	31	2.1	2.1	177	157	19.1	4 900	7 000	**NU312EA	NJ	NUP	N
	130	46	2.1	2.1	187	188	22.9	4 800	5 700	**NU2312	NJ	NUP	N
	130	46	2.1	2.1	263	262	32.0	4 400	6 200	**NU212EA	NJ	NUP	N
	150	35	2.1	2.1	185	168	20.2	3 900	4 600	NU412	NJ	NUP	N
65	100	18	1.1	1	45.5	51.0	6.30	7 000	8 200	NU1013	NJ	NUP	N
	120	23	1.5	1.5	93.0	94.5	11.5	5 900	7 000	**NU213	NJ	NUP	N
	120	23	1.5	1.5	127	119	14.5	5 400	7 600	**NU213EA	NJ	NUP	N
	120	31	1.5	1.5	133	149	18.2	5 400	6 300	**NU2213	NJ	NUP	N
	120	31	1.5	1.5	176	181	22.1	4 800	6 700	**NU2213EA	NJ	NUP	N
	140	33	2.1	2.1	150	139	16.8	5 100	6 000	**NU313	NJ	NUP	N
	140	33	2.1	2.1	213	191	23.1	4 600	6 500	**NU313EA	NJ	NUP	N
	140	48	2.1	2.1	208	212	25.7	4 400	5 200	**NU2313	NJ	NUP	N
	140	48	2.1	2.1	293	287	34.5	4 100	5 800	**NU2313EA	NJ	NUP	N
160	37	2.1	2.1	202	186	21.9	3 600	4 300	NU413	NJ	NUP	N	
70	110	20	1.1	1	64.5	70.5	8.60	6 500	7 600	NU1014	NJ	NUP	N
	125	24	1.5	1.5	92.5	95.0	11.6	5 500	6 500	**NU214	NJ	NUP	N
	125	24	1.5	1.5	140	137	16.7	5 000	7 100	**NU214EA	NJ	NUP	N
	125	31	1.5	1.5	132	151	18.4	5 000	5 900	**NU2214	NJ	NUP	N
	125	31	1.5	1.5	184	194	23.7	4 500	6 200	**NU2214EA	NJ	NUP	N
	150	35	2.1	2.1	175	168	20.0	4 700	5 500	**NU314	NJ	NUP	N
	150	35	2.1	2.1	242	222	26.2	4 200	6 000	**NU314EA	NJ	NUP	N
	150	51	2.1	2.1	247	262	31.0	4 100	4 800	**NU2314	NJ	NUP	N
	150	51	2.1	2.1	325	325	38.0	3 800	5 300	**NU2314EA	NJ	NUP	N
180	42	3	3	253	236	26.8	3 400	4 000	NU414	NJ	NUP	N	
75	115	20	1.1	1	66.5	74.5	9.10	6 100	7 100	NU1015	NJ	NUP	N
	130	25	1.5	1.5	107	111	13.4	5 100	6 000	**NU215	NJ	NUP	N
	130	25	1.5	1.5	154	156	18.9	4 700	6 600	**NU215EA	NJ	NUP	N
	130	31	1.5	1.5	144	162	19.6	4 700	5 500	**NU2215	NJ	NUP	N
	130	31	1.5	1.5	191	207	25.0	4 200	5 900	**NU2215EA	NJ	NUP	N
	160	37	2.1	2.1	211	205	23.8	4 400	5 200	**NU315	NJ	NUP	N
	160	37	2.1	2.1	284	263	30.5	4 000	5 600	**NU315EA	NJ	NUP	N
	160	55	2.1	2.1	286	300	35.0	3 800	4 500	**NU2315	NJ	NUP	N
	160	55	2.1	2.1	390	395	45.5	3 500	4 900	**NU2315EA	NJ	NUP	N
190	45	3	3	291	274	30.5	3 200	3 700	NU415	NJ	NUP	N	

1) Smallest allowable dimension for chamfer dimension r or r₁.
 2) This value is for machined cages; when pressed cages are used, 80% of this value is acceptable.
 3) Bearing numbers marked "*" designate ULTAGE series bearings. 4) Bearing marked "**" are going to be integrated with ULTAGE Series.

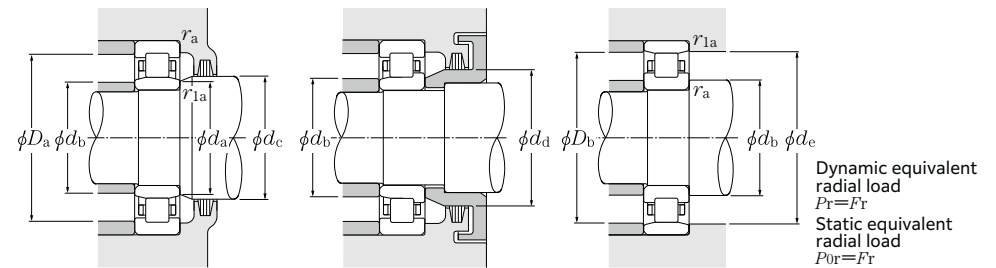

NF type	Dimension				Installation-related dimensions								Mass		
	F _w	E _w	d ₁	d _a	d _e	d _b	d _c	d _d	D _a	D _b	r _{as}	r _{1as}	NU type	N type	
NF	77	113	84.2	71	71	75	79	86	119	119	116	2	2	1.8	1.76
NF	77	115	84.6	71	71	75	79	86	119	119	117	2	2	2.05	1.77
—	77	113	84.2	71	71	75	79	86	119	119	116	2	2	2.71	2.66
NF	77	115	84.6	71	71	75	79	86	119	119	117	2	2	2.96	2.73
NF	83	127	91.8	71	71	82	85	94	139	139	128	2	2	3	2.93
—	74.5	90.5	77.7	70	71.5	73	76	78.5	93.5	95	91.5	1	1	0.485	0.477
NF	79.6	105.6	84.8	73	73	77	81	87	112	112	108	1.5	1.5	1.02	1
NF	78.5	108.5	84.5	73	73	77	81	87	112	112	110	1.5	1.5	1.21	1.01
—	79.6	105.6	84.8	73	73	77	81	87	112	112	108	1.5	1.5	1.4	1.37
NF	78.5	108.5	84.5	73	73	77	81	87	112	112	110	1.5	1.5	1.6	1.44
NF	83.5	121.5	91	76	76	81	85	93	129	129	125	2	2	2.23	2.18
NF	82.5	124.5	91	76	76	81	85	93	129	129	127	2	2	2.54	2.2
—	83.5	121.5	91	76	76	81	85	93	129	129	125	2	2	3.27	3.2
NF	82.5	124.5	91	76	76	81	85	93	129	129	127	2	2	3.48	3.25
NF	89.3	135.3	98.5	76	76	88	91	100	149	149	137	2	2	3.6	3.5
—	80	100	84	75	76.5	78	82	85	103.5	105	101	1	1	0.699	0.689
NF	84.5	110.5	89.6	78	78	82	86	92	117	117	114	1.5	1.5	1.12	1.1
NF	83.5	113.5	89.5	78	78	82	86	92	117	117	115	1.5	1.5	1.3	1.13
—	84.5	110.5	89.6	78	78	82	86	92	117	117	114	1.5	1.5	1.47	1.44
NF	83.5	113.5	89.5	78	78	82	86	92	117	117	115	1.5	1.5	1.7	1.52
NF	90	130	98	81	81	87	92	100	139	139	134	2	2	2.71	2.65
NF	89	133	98	81	81	87	92	100	139	139	136	2	2	3.1	2.75
—	90	130	98	81	81	87	92	100	139	139	134	2	2	3.98	3.9
NF	89	133	98	81	81	87	92	100	139	139	136	2	2	4.25	3.95
NF	100	152	110.5	83	83	99	102	112	167	167	153	2.5	2.5	5.24	5.1
—	85	105	89	80	81.5	83	87	90	108.5	110	106	1	1	0.738	0.727
NF	88.5	116.5	94	83	83	87	90	96	122	122	120	1.5	1.5	1.23	1.21
NF	88.5	118.5	94.5	83	83	87	90	96	122	122	120	1.5	1.5	1.41	1.28
—	88.5	116.5	94	83	83	87	90	96	122	122	120	1.5	1.5	1.55	1.52
NF	88.5	118.5	94.5	83	83	87	90	96	122	122	120	1.5	1.5	1.79	1.61
NF	95.5	139.5	104.2	86	86	93	97	106	149	149	143	2	2	3.28	3.21
NF	95	143	104.6	86	86	93	97	106	149	149	146	2	2	3.74	3.28
—	95.5	139.5	104.2	86	86	93	97	106	149	149	143	2	2	4.87	4.77
NF	95	143	104.6	86	86	93	97	106	149	149	—	2	2	5.25	4.85
NF	104.5	160.5	116	88	88	103	107	118	177	177	162	2.5	2.5	6.22	6.06

5) Does not apply to the sides of the outer ring rib of type NF bearings.

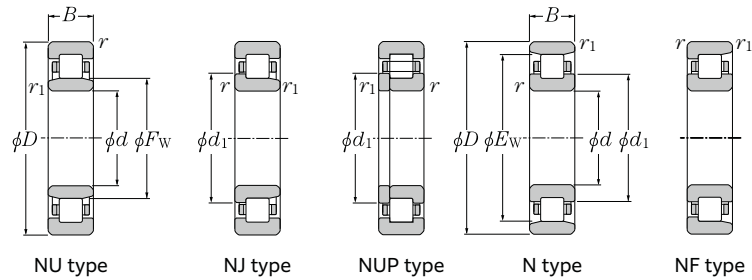

d 80 ~ 95mm

d	Boundary dimensions				Basic load rating		Fatigue load limit kN C _u	Allowable speed ²⁾		Bearing number ^{3) 4)}			
	D	B	r _{s min} ¹⁾	r _{1s min} ¹⁾	C _r	C _{0r}		Grease lubrication	Oil lubrication	NU type	NJ type	NUP type	N type
80	125	22	1.1	1	80.0	90.5	11.0	5 700	6 700	NU1016	NJ	NUP	N
	140	26	2	2	118	122	14.5	4 800	5 700	**NU216	NJ	NUP	N
	140	26	2	2	165	167	19.7	4 400	6 100	**NU216EA	NJ	NUP	N
	140	33	2	2	163	186	22.0	4 400	5 100	**NU2216	NJ	NUP	N
	140	33	2	2	220	243	28.7	3 900	5 500	**NU2216EA	NJ	NUP	N
	170	39	2.1	2.1	211	207	23.7	4 100	4 800	NU316	NJ	NUP	N
	170	39	2.1	2.1	284	282	32.0	3 700	4 400	NU316E	NJ	NUP	N
	170	58	2.1	2.1	305	330	38.0	3 600	4 200	NU2316	NJ	NUP	N
	170	58	2.1	2.1	395	430	49.0	3 300	3 900	NU2316E	NJ	NUP	N
200	48	3	3	330	315	34.5	3 000	3 500	NU416	NJ	NUP	N	
85	130	22	1.1	1	82.5	95.5	11.4	5 400	6 300	NU1017	NJ	NUP	N
	150	28	2	2	134	140	16.3	4 500	5 300	**NU217	NJ	NUP	N
	150	28	2	2	198	199	23.0	4 100	5 800	**NU217EA	NJ	NUP	N
	150	36	2	2	188	218	25.3	4 100	4 800	**NU2217	NJ	NUP	N
	150	36	2	2	257	279	32.5	3 700	5 200	**NU2217EA	NJ	NUP	N
	180	41	3	3	235	228	25.6	3 900	4 600	NU317	NJ	NUP	N
	180	41	3	3	325	330	37.0	3 500	4 100	NU317E	NJ	NUP	N
	180	60	3	3	350	380	43.0	3 400	4 000	NU2317	NJ	NUP	N
180	60	3	3	435	485	54.0	3 100	3 700	NU2317E	NJ	NUP	N	
90	140	24	1.5	1.1	98.0	114	13.4	5 100	5 900	NU1018	NJ	NUP	N
	160	30	2	2	169	178	20.3	4 300	5 000	**NU218	NJ	NUP	N
	160	30	2	2	215	217	24.7	3 900	5 500	**NU218EA	NJ	NUP	N
	160	40	2	2	219	248	28.3	3 900	4 600	**NU2218	NJ	NUP	N
	160	40	2	2	286	315	35.5	3 500	4 900	**NU2218EA	NJ	NUP	N
	190	43	3	3	266	265	29.3	3 700	4 300	NU318	NJ	NUP	N
	190	43	3	3	350	355	39.0	3 300	3 900	NU318E	NJ	NUP	N
	190	64	3	3	360	395	43.5	3 200	3 800	NU2318	NJ	NUP	N
190	64	3	3	485	535	58.5	2 900	3 400	NU2318E	NJ	NUP	N	
95	145	24	1.5	1.1	101	120	13.9	4 800	5 600	NU1019	NJ	NUP	N
	170	32	2.1	2.1	184	195	21.8	4 000	4 700	**NU219	NJ	NUP	N
	170	32	2.1	2.1	260	265	29.6	3 600	5 200	**NU219EA	NJ	NUP	N
	170	43	2.1	2.1	256	298	33.5	3 600	4 300	NU2219	NJ	NUP	N
	170	43	2.1	2.1	315	370	41.5	3 300	3 800	NU2219E	NJ	NUP	N
	200	45	3	3	287	289	31.5	3 400	4 000	NU319	NJ	NUP	N
	200	45	3	3	370	385	42.0	3 100	3 600	NU319E	NJ	NUP	N

1) Smallest allowable dimension for chamfer dimension r or r₁.
 2) This value is for machined cages; when pressed cages are used, 80% of this value is acceptable.
 3) Bearing numbers marked "*" designate ULTAGE series bearings. 4) Bearing marked "**" are going to be integrated with ULTAGE Series.

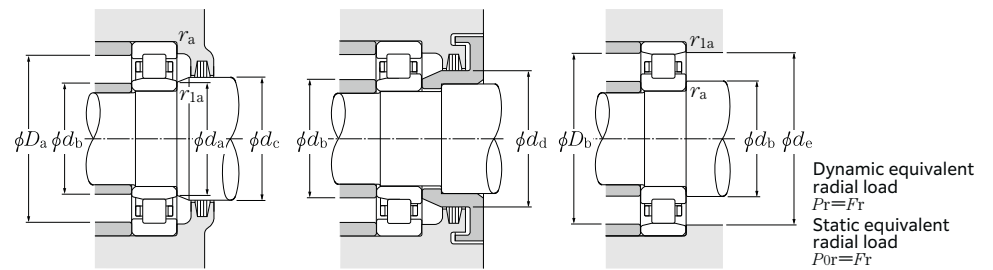

Dynamic equivalent radial load
 $P_r = F_r$
 Static equivalent radial load
 $P_{0r} = F_r$

NF type	Dimension				Installation-related dimensions									Mass	
	F _w	E _w	d ₁	d _a Min.	d _e Min.	d _b Max.	d _c Min.	d _d Min.	D _a Max.	D _b Max.	r _{as} Min. ⁵⁾	r _{1as} Max.	NU type (approx.)	N type (approx.)	
—	91.5	113.5	95.9	85	86.5	90	94	97	118.5	120	114.5	1	1	0.98	0.965
NF	95.3	125.3	101.2	89	89	94	97	104	131	131	128	2	2	1.5	1.47
NF	95.3	127.3	101.7	89	89	94	97	104	131	131	128.5	2	2	1.67	1.56
—	95.3	125.3	101.2	89	89	94	97	104	131	131	128	2	2	1.93	1.89
NF	95.3	127.3	101.7	89	89	94	97	104	131	131	128.5	2	2	2.12	2.02
NF	103	147	111.8	91	91	99	105	114	159	159	151	2	2	3.86	3.77
NF	101	151	111	91	91	99	105	114	159	159	154	2	2	4.22	4.12
—	103	147	111.8	91	91	99	105	114	159	159	151	2	2	5.79	5.67
NF	101	151	111	91	91	99	105	114	159	159	154	2	2	6.25	5.78
NF	110	170	122	93	93	109	112	124	187	187	172	2.5	2.5	7.32	7.14
—	96.5	118.5	100.9	90	91.5	95	99	102	123.5	125	119.5	1	1	1.03	1.01
NF	101.8	133.8	108.2	94	94	99	104	110	141	141	137	2	2	1.87	1.83
NF	100.5	136.5	107.7	94	94	99	104	110	141	141	138	2	2	2.11	1.93
—	101.8	133.8	108.2	94	94	99	104	110	141	141	137	2	2	2.44	2.39
NF	100.5	136.5	107.7	94	94	99	104	110	141	141	138	2	2	2.68	2.52
NF	108	156	117.5	98	98	106	110	119	167	167	160	2.5	2.5	4.54	4.44
—	108	—	118.4	98	—	106	110	119	167	—	—	2.5	2.5	4.81	—
—	108	156	117.5	98	98	106	110	119	167	167	160	2.5	2.5	6.7	6.57
—	108	—	118.4	98	—	106	110	119	167	—	—	2.5	2.5	7.16	—
—	103	127	107.8	96.5	98	101	106	109	132	133.5	129	1.5	1	1.33	1.31
NF	107	143	114.2	99	99	105	109	116	151	151	146	2	2	2.3	2.25
NF	107	145	114.6	99	99	105	109	116	151	151	147	2	2	2.44	2.37
—	107	143	114.2	99	99	105	109	116	151	151	146	2	2	3.1	3.04
NF	107	145	114.6	99	99	105	109	116	151	151	147	2	2	3.33	3.2
NF	115	165	125	103	103	111	117	127	177	177	169	2.5	2.5	5.3	5.18
—	113.5	—	124.7	103	—	111	117	127	177	—	—	2.5	2.5	5.72	—
—	115	165	125	103	103	111	117	127	177	177	169	2.5	2.5	7.95	7.79
—	113.5	—	124.7	103	—	111	117	127	177	—	—	2.5	2.5	8.56	—
—	108	132	112.8	101.5	103	106	111	114	137	138.5	134	1.5	1	1.4	1.38
NF	113.5	151.5	121	106	106	111	116	123	159	159	155	2	2	2.78	2.72
NF	112.5	154.5	121	106	106	111	116	123	159	159	155.5	2	2	3.02	2.85
—	113.5	151.5	121	106	106	111	116	123	159	159	155	2	2	3.79	3.71
NF	112.5	154.5	121	106	106	111	116	123	159	159	156.5	2	2	4.14	3.84
NF	121.5	173.5	132	108	108	119	124	134	187	187	178	2.5	2.5	6.13	5.99
—	121.5	—	132.7	108	—	119	124	134	187	—	—	2.5	2.5	6.62	—

5) Does not apply to the sides of the outer ring rib of type NF bearings.

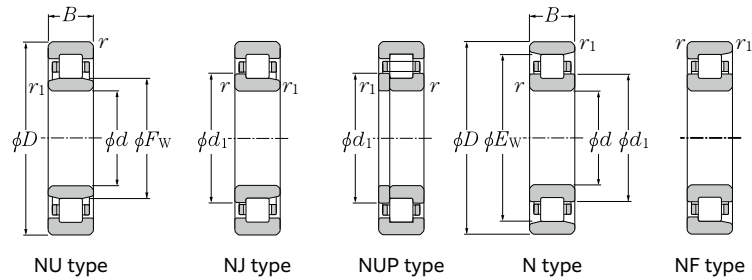

d 95 ~ 130mm

d	Boundary dimensions				Basic load rating		Fatigue load limit kN C _u	Allowable speed ²⁾		Bearing number			
	D	B	r _{s min} ¹⁾	r _{1s min} ¹⁾	d _r	C _{0r}		Grease lubrication	Oil lubrication	min ⁻¹	min ⁻¹	NU type	NJ type
95	200	67	3	3	410	460	50.0	3 000	3 500	NU2319	NJ	NUP	N
	200	67	3	3	510	585	63.0	2 700	3 200	NU2319E	NJ	NUP	—
100	150	24	1.5	1.1	103	126	14.4	4 600	5 400	NU1020	NJ	NUP	N
	180	34	2.1	2.1	203	217	23.9	3 800	4 500	NU2220	NJ	NUP	N
	180	34	2.1	2.1	277	305	33.5	3 500	4 100	NU220E	NJ	NUP	—
	180	46	2.1	2.1	286	340	37.5	3 500	4 100	NU2220	NJ	NUP	N
	180	46	2.1	2.1	370	445	49.0	3 100	3 600	NU2220E	NJ	NUP	—
	215	47	3	3	330	335	36.0	3 300	3 800	NU320	NJ	NUP	N
	215	47	3	3	420	425	45.0	2 900	3 500	NU320E	NJ	NUP	—
	215	73	3	3	455	505	54.0	2 900	3 400	NU2320	NJ	NUP	N
215	73	3	3	630	715	76.0	2 600	3 100	NU2320E	NJ	NUP	—	
105	160	26	2	1.1	117	142	16.0	4 300	5 100	NU1021	NJ	NUP	N
	190	36	2.1	2.1	223	241	26.1	3 600	4 300	NU221	NJ	NUP	N
	225	49	3	3	355	360	37.5	3 100	3 700	NU321	NJ	NUP	N
110	170	28	2	1.1	146	174	19.2	4 100	4 800	NU1022	NJ	NUP	N
	200	38	2.1	2.1	266	290	31.0	3 400	4 000	NU222	NJ	NUP	N
	200	38	2.1	2.1	325	365	39.0	3 100	3 700	NU222E	NJ	NUP	—
	200	53	2.1	2.1	350	415	44.0	3 100	3 700	NU2222	NJ	NUP	N
	200	53	2.1	2.1	425	515	55.0	2 800	3 300	NU2222E	NJ	NUP	—
	240	50	3	3	395	400	41.5	3 000	3 500	NU322	NJ	NUP	N
	240	50	3	3	500	525	54.0	2 700	3 100	NU322E	NJ	NUP	—
	240	80	3	3	670	790	81.5	2 600	3 100	NU2322	NJ	NUP	N
240	80	3	3	750	880	90.5	2 400	2 800	NU2322E	NJ	NUP	—	
120	180	28	2	1.1	154	191	20.6	3 800	4 400	NU1024	NJ	NUP	N
	215	40	2.1	2.1	288	320	33.5	3 200	3 700	NU224	NJ	NUP	N
	215	40	2.1	2.1	370	420	44.0	2 900	3 400	NU224E	NJ	NUP	—
	215	58	2.1	2.1	385	460	48.0	2 900	3 400	NU2224	NJ	NUP	N
	215	58	2.1	2.1	500	620	64.5	2 600	3 000	NU2224E	NJ	NUP	—
	260	55	3	3	500	510	51.0	2 700	3 200	NU324	NJ	NUP	N
	260	55	3	3	585	610	61.0	2 400	2 800	NU324E	NJ	NUP	—
	260	86	3	3	785	920	92.5	2 400	2 800	NU2324	NJ	NUP	N
260	86	3	3	880	1 030	103	2 200	2 500	NU2324E	NJ	NUP	—	
130	200	33	2	1.1	191	238	24.9	3 400	4 000	NU1026	NJ	NUP	N

1) Smallest allowable dimension for chamfer dimension r or r₁.
2) This value is for machined cages; when pressed cages are used, 80% of this value is acceptable.

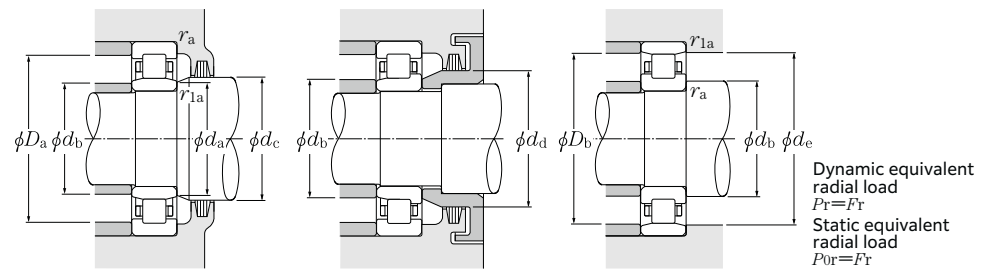

Dynamic equivalent radial load
 $P_r = F_r$
Static equivalent radial load
 $P_{0r} = F_r$

NF type	Dimension				Installation-related dimensions									Mass	
	F _w	E _w	d ₁	d ₁ Min.	d _e Min.	d _b Max.	d _c Min.	d _d Min.	d _a Max.	D _b Max.	D _b Min. ³⁾	r _{as} Max.	r _{1as} Max.	NU type (approx.)	N type (approx.)
—	121.5	173.5	132	108	108	119	124	134	187	187	178	2.5	2.5	9.2	9.02
—	121.5	—	132.7	108	—	119	124	134	187	—	—	2.5	2.5	9.8	—
—	113	137	117.8	106.5	108	111	116	119	142	143.5	139	1.5	1	1.45	1.43
NF	120	160	128	111	111	117	122	130	169	169	164	2	2	3.33	3.26
—	119	—	128	111	—	117	122	130	169	—	—	2	2	3.66	—
—	120	160	128	111	111	117	122	130	169	169	164	2	2	4.57	4.48
—	119	—	128	111	—	117	122	130	169	—	—	2	2	5.01	—
NF	129.5	185.5	140.5	113	113	125	132	143	202	202	190	2.5	2.5	7.49	7.32
—	127.5	—	140.3	113	—	125	132	143	202	—	—	2.5	2.5	8.57	—
—	129.5	185.5	140.5	113	113	125	132	143	202	202	190	2.5	2.5	11.7	11.5
—	127.5	—	140.3	113	—	125	132	143	202	—	—	2.5	2.5	12.8	—
—	119.5	145.5	124.7	111.5	114	118	122	126	151	153.5	147.5	2	1	1.84	1.81
NF	126.8	168.8	135	116	116	124	129	137	179	179	173	2	2	3.95	3.87
NF	135	195	147	118	118	132	137	149	212	212	199	2.5	2.5	8.53	8.33
—	125	155	131	116.5	119	124	128	132	161	163.5	157	2	1	2.33	2.3
NF	132.5	178.5	141.5	121	121	130	135	144	189	189	182	2	2	4.63	4.54
—	132.5	—	142.1	121	—	130	135	144	189	—	—	2	2	4.27	—
—	132.5	178.5	141.5	121	121	130	135	144	189	189	182	2	2	6.56	6.43
—	132.5	—	142.1	121	—	130	135	144	189	—	—	2	2	7.4	—
NF	143	207	155.5	123	123	140	145	158	227	227	211	2.5	2.5	10	9.77
—	143	—	156.6	123	—	140	145	158	227	—	—	2.5	2.5	11.1	11.4
—	143	207	155.5	123	123	140	145	158	227	227	211	2.5	2.5	17.1	16.8
—	143	—	156.6	123	—	140	145	158	227	—	—	2.5	2.5	19.4	—
—	135	165	141	126.5	129	134	138	142	171	173.5	167	2	1	2.44	2.4
NF	143.5	191.5	153	131	131	141	146	156	204	204	196	2	2	5.57	5.46
—	143.5	—	153.9	131	—	141	146	156	204	—	—	2	2	5.97	—
—	143.5	191.5	153	131	131	141	146	156	204	204	196	2	2	8.19	8.03
—	143.5	—	153.9	131	—	141	146	156	204	—	—	2	2	9.18	—
NF	154	226	168.5	133	133	151	156	171	247	247	230	2.5	2.5	12.8	12.5
—	154	—	169.2	133	—	151	156	171	247	—	—	2.5	2.5	13.9	—
—	154	226	168.5	133	133	151	156	171	247	247	230	2.5	2.5	21.5	21.1
—	154	—	169.2	133	—	151	156	171	247	—	—	2.5	2.5	26.1	—
—	148	182	154.8	136.5	139	146	151	156	191	193.5	184	2	1	3.69	3.63

3) Does not apply to the sides of the outer ring rib of type NF bearings.

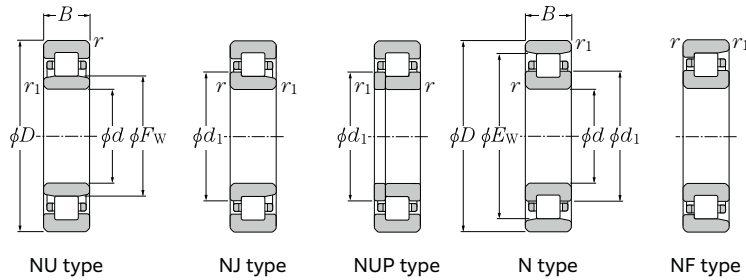

d 130 ~ 160mm

Boundary dimensions				Basic load rating			Fatigue load limit kN C _u	Allowable speed ²⁾		Bearing number			
d	D	B	r _{s min} ¹⁾	r _{1s min} ¹⁾	C _r	C _{0r}		Grease lubrication	Oil lubrication	NU type	NJ type	NUP type	N type
130	230	40	3	3	300	340	35.0	2 900	3 400	NU226	NJ	NUP	N
	230	40	3	3	405	455	46.0	2 600	3 100	NU226E	NJ	NUP	—
	230	64	3	3	420	530	54.0	2 600	3 100	NU2226	NJ	NUP	N
	230	64	3	3	590	735	75.0	2 300	2 700	NU2226E	NJ	NUP	—
	280	58	4	4	620	665	65.5	2 500	2 900	NU326	NJ	NUP	N
	280	58	4	4	685	735	72.0	2 200	2 600	NU326E	NJ	NUP	—
	280	93	4	4	930	1 130	111	2 200	2 600	NU2326	NJ	NUP	N
	280	93	4	4	1 020	1 230	121	2 000	2 300	NU2326E	NJ	NUP	—
140	210	33	2	1.1	195	250	25.7	3 200	3 800	NU1028	NJ	NUP	N
	250	42	3	3	345	400	39.5	2 700	3 100	NU228	NJ	NUP	N
	250	42	3	3	435	515	51.0	2 400	2 800	NU228E	NJ	NUP	—
	250	68	3	3	495	635	63.5	2 400	2 800	NU2228	NJ	NUP	N
	250	68	3	3	635	835	83.0	2 100	2 500	NU2228E	NJ	NUP	—
	300	62	4	4	685	745	72.0	2 300	2 700	NU328	NJ	NUP	N
	300	62	4	4	735	795	76.5	2 100	2 400	NU328E	NJ	NUP	—
	300	102	4	4	1 020	1 250	120	2 000	2 300	NU2328	NJ	NUP	N
300	102	4	4	1 130	1 380	133	1 800	2 100	NU2328E	NJ	NUP	—	
150	225	35	2.1	1.5	224	294	29.6	3 000	3 500	NU1030	NJ	NUP	N
	270	45	3	3	380	435	42.5	2 500	2 900	NU230	NJ	NUP	N
	270	45	3	3	495	595	58.0	2 200	2 600	NU230E	NJ	NUP	—
	270	73	3	3	555	710	69.5	2 200	2 600	NU2230	NJ	NUP	N
	270	73	3	3	735	980	95.5	2 000	2 400	NU2230E	NJ	NUP	—
	320	65	4	4	735	805	76.0	2 100	2 500	NU330	NJ	NUP	N
	320	65	4	4	840	920	86.5	1 900	2 300	NU330E	NJ	NUP	—
	320	108	4	4	1 130	1 400	132	1 900	2 200	NU2330	NJ	NUP	N
320	108	4	4	1 290	1 600	150	1 700	2 000	NU2330E	NJ	NUP	—	
160	240	38	2.1	1.5	263	340	34.0	2 800	3 300	NU1032	NJ	NUP	N
	290	48	3	3	475	570	54.5	2 300	2 700	NU232	NJ	NUP	N
	290	48	3	3	555	665	63.5	2 100	2 400	NU232E	NJ	NUP	—
	290	80	3	3	700	940	90.0	2 100	2 400	NU2232	NJ	NUP	N
	290	80	3	3	895	1 190	114	1 900	2 200	NU2232E	NJ	NUP	—
	340	68	4	4	775	875	81.0	2 000	2 300	NU332	NJ	NUP	N
	340	68	4	4	950	1 050	97.5	1 800	2 100	NU332E	NJ	NUP	—
	340	114	4	4	1 190	1 520	141	1 700	2 000	NU2332	NJ	NUP	N
340	114	4	4	1 460	1 820	168	1 600	1 900	NU2332E	NJ	NUP	—	

1) Smallest allowable dimension for chamfer dimension r or r₁.

2) This value is for machined cages; when pressed cages are used, 80% of this value is acceptable.

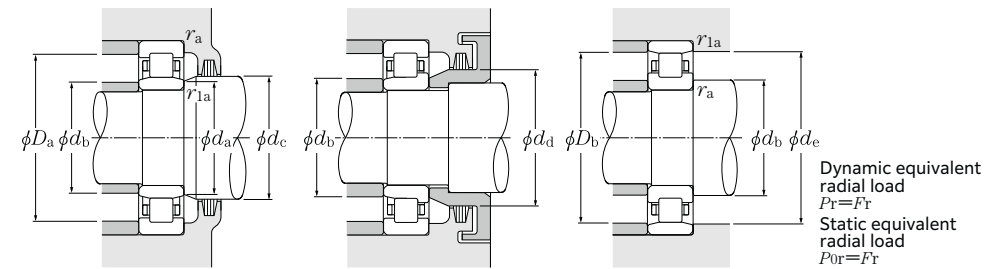

Dynamic equivalent radial load
 $P_r = F_r$
Static equivalent radial load
 $P_{0r} = F_r$

NF type	Dimension						Installation-related dimensions								Mass	
	F _w	E _w	d ₁	d _a	d _e	d _c	d _b	d _c	d _d	D _a	D _b	r _{as}	r _{1as}	NU type	N type	
NF	156	204	165.5	143	143	151	158	168	217	217	208	2.5	2.5	6.3	6.17	
—	153.5	—	164.7	143	—	151	158	168	217	—	—	2.5	2.5	6.9	—	
—	156	204	165.5	143	143	151	158	168	217	217	208	2.5	2.5	10.2	10	
—	153.5	—	164.7	143	—	151	158	168	217	—	—	2.5	2.5	11.8	—	
NF	167	243	182	146	146	164	169	184	264	264	247	3	3	17.4	17	
—	167	—	183	146	—	164	169	184	264	—	—	3	3	19.4	—	
—	167	243	182	146	146	164	169	184	264	264	247	3	3	26.9	26.4	
—	167	—	183	146	—	164	169	184	264	—	—	3	3	30.9	—	
—	158	192	164.8	146.5	149	156	161	166	201	203.5	194	2	1	4.05	3.98	
NF	169	221	179.5	153	153	166	171	182	237	237	225	2.5	2.5	7.88	7.72	
—	169	—	180.2	153	—	166	171	182	237	—	—	2.5	2.5	8.73	—	
—	169	221	179.5	153	153	166	171	182	237	237	225	2.5	2.5	12.9	12.6	
—	169	—	180.2	153	—	166	171	182	237	—	—	2.5	2.5	15.8	—	
NF	180	260	196	156	156	176	182	198	284	284	265	3	3	21.2	20.7	
—	180	—	196.8	156	—	176	182	198	284	—	—	3	3	23.2	—	
—	180	260	196	156	156	176	182	198	284	284	265	3	3	33.8	33.1	
—	180	—	196.8	156	—	176	182	198	284	—	—	3	3	38.7	—	
—	169.5	205.5	176.7	158	161	167	173	178	214	217	207.5	2	1.5	4.77	4.7	
NF	182	238	193	163	163	179	184	196	257	257	242	2.5	2.5	9.92	9.72	
—	182	—	194	163	—	179	184	196	257	—	—	2.5	2.5	11	—	
—	182	238	193	163	163	179	184	196	257	257	242	2.5	2.5	16.3	16	
—	182	—	194	163	—	179	184	196	257	—	—	2.5	2.5	19.7	—	
NF	193	277	210	166	166	190	195	213	304	304	282	3	3	25.3	24.7	
—	193	—	211	166	—	190	195	213	304	—	—	3	3	28.4	—	
—	193	277	210	166	166	190	195	213	304	304	282	3	3	40.6	39.8	
—	193	—	211	166	—	190	195	213	304	—	—	3	3	47.2	—	
—	180	220	188	168	171	178	184	189	229	232	222	2	1.5	5.9	5.81	
NF	195	255	207	173	173	192	197	210	277	277	259	2.5	2.5	13.7	13.4	
—	195	—	207.8	173	—	192	197	210	277	—	—	2.5	2.5	15.6	—	
—	195	255	207	173	173	192	197	210	277	277	259	2.5	2.5	22	21.6	
—	193	—	206.6	173	—	192	197	210	277	—	—	2.5	2.5	25.1	—	
NF	208	292	225	176	176	200	211	228	324	324	297	3	3	31.3	30.6	
—	204	—	223.2	176	—	200	211	228	324	—	—	3	3	34	—	
—	208	292	225	176	176	200	211	228	324	324	297	3	3	50.5	49.5	
—	204	—	223.2	176	—	200	211	228	324	—	—	3	3	56	—	

3) Does not apply to the sides of the outer ring rib of type NF bearings.

Cylindrical Roller Bearings

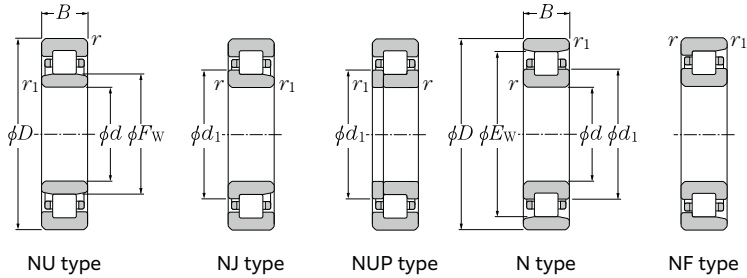

d 170 ~ 220mm

d	Boundary dimensions				Basic load rating		Fatigue load limit kN C_u	Allowable speed ²⁾		Bearing number			
	D	B	$r_{s \text{ min}}^{1)}$	$r_{1s \text{ min}}^{1)}$	dynamic kN C_r	static kN C_{0r}		Grease lubrication	Oil lubrication	NU type	NJ type	NUP type	N type
170	260	42	2.1	2.1	310	400	38.5	2 600	3 000	NU1034	NJ	NUP	N
	310	52	4	4	530	635	59.5	2 200	2 500	NU234	NJ	NUP	N
	310	52	4	4	670	800	75.0	2 000	2 300	NU234E	NJ	NUP	—
	310	86	4	4	795	1 080	101	2 000	2 300	NU2234	NJ	NUP	N
	310	86	4	4	1 070	1 410	132	1 800	2 100	NU2234E	NJ	NUP	—
	360	72	4	4	885	1 010	92.0	1 800	2 200	NU334	NJ	NUP	N
	360	120	4	4	1 360	1 750	159	1 600	1 900	NU2334	NJ	NUP	N
180	280	46	2.1	2.1	380	485	46.5	2 400	2 900	NU1036	NJ	NUP	N
	320	52	4	4	550	675	62.5	2 000	2 400	NU236	NJ	NUP	N
	320	52	4	4	695	850	78.5	1 800	2 200	NU236E	NJ	NUP	—
	320	86	4	4	825	1 140	106	1 800	2 200	NU2236	NJ	NUP	N
	320	86	4	4	1 120	1 510	139	1 600	1 900	NU2236E	NJ	NUP	—
	380	75	4	4	1 000	1 150	103	1 700	2 000	NU336	NJ	NUP	N
	380	126	4	4	1 530	1 990	179	1 500	1 800	NU2336	NJ	NUP	N
190	290	46	2.1	2.1	390	510	48.0	2 300	2 700	NU1038	NJ	NUP	N
	340	55	4	4	615	770	70.0	1 900	2 200	NU238	NJ	NUP	N
	340	55	4	4	770	955	86.5	1 700	2 000	NU238E	NJ	NUP	—
	340	92	4	4	920	1 290	117	1 700	2 000	NU2238	NJ	NUP	N
	340	92	4	4	1 220	1 670	152	1 500	1 800	NU2238E	NJ	NUP	—
	400	78	5	5	1 080	1 260	111	1 600	1 900	NU338	NJ	NUP	N
	400	132	5	5	1 680	2 220	196	1 400	1 700	NU2338	NJ	NUP	N
200	310	51	2.1	2.1	430	580	53.5	2 200	2 600	NU1040	NJ	NUP	N
	360	58	4	4	690	865	77.5	1 800	2 100	NU240	NJ	NUP	N
	360	58	4	4	850	1 060	95.0	1 600	1 900	NU240E	NJ	NUP	—
	360	98	4	4	1 020	1 440	129	1 600	1 900	NU2240	NJ	NUP	N
	360	98	4	4	1 350	1 870	167	1 500	1 700	NU2240E	NJ	NUP	—
	420	80	5	5	1 080	1 270	111	1 500	1 800	NU340	NJ	NUP	N
	420	138	5	5	1 680	2 240	195	1 400	1 600	NU2340	NJ	NUP	N
220	340	56	3	3	555	750	67.0	2 000	2 300	NU1044	NJ	NUP	N
	400	65	4	4	845	1 080	94	1 600	1 900	NU244	NJ	NUP	N
	400	108	4	4	1 260	1 810	157	1 500	1 700	NU2244	NJ	NUP	N
	460	88	5	5	1 320	1 570	133	1 400	1 600	NU344	NJ	NUP	N
	460	145	5	5	1 970	2 620	222	1 200	1 400	NU2344	NJ	NUP	N

1) Smallest allowable dimension for chamfer dimension r or r_1 .

2) This value is for machined cages; when pressed cages are used, 80% of this value is acceptable.

Cylindrical Roller Bearings

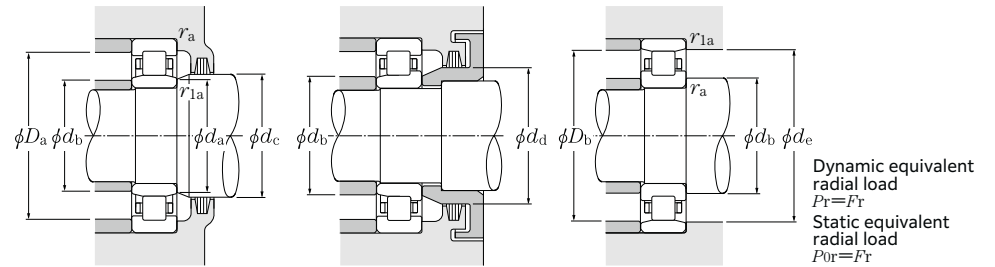

NF type	Dimension				Installation-related dimensions								Mass			
	F_w	E_w	d_1	mm	d_a	d_e	d_b	d_c	d_d	mm	D_a	D_b	r_{as}	r_{1as}	kg	kg
—	193	237	201.8	Min.	Min.	Max.	Min.	Min.	Max.	Max.	Max.	Min. ³⁾	Max.	Max.	NU type (approx.)	N type
—	193	237	201.8	181	181	190	197	203	249	249	239	2	2	7.88	7.76	
NF	208	272	220.5	186	186	204	211	223	294	294	277	3	3	17	16.7	
—	207	—	221.4	186	—	204	211	223	294	—	—	3	3	19.6	—	
—	208	272	220.5	186	186	204	211	223	294	294	277	3	3	27.2	26.7	
—	205	—	220.2	186	—	204	211	223	294	—	—	3	3	31	—	
NF	220	310	238	186	186	216	223	241	344	344	315	3	3	37	36.1	
—	220	310	238	186	186	216	223	241	344	344	315	3	3	59.5	58.3	
—	205	255	215	191	191	203	209	216	269	269	257	2	2	10.3	10.1	
NF	218	282	230.5	196	196	214	221	233	304	304	287	3	3	17.7	17.3	
—	217	—	231.4	196	—	214	221	233	304	—	—	3	3	20.4	—	
—	218	282	230.5	196	196	214	221	233	304	304	287	3	3	28.4	27.8	
—	215	—	230.2	196	—	214	221	233	304	—	—	3	3	31.9	—	
NF	232	328	252	196	196	227	235	255	364	364	333	3	3	44.2	43.2	
—	232	328	252	196	196	227	235	255	364	364	333	3	3	69.5	68.1	
—	215	265	225	201	201	213	219	226	279	279	267	2	2	10.7	10.5	
NF	231	299	244.5	206	206	227	234	247	324	324	304	3	3	21.3	20.8	
—	230	—	245.2	206	—	227	234	247	324	—	—	3	3	24.2	—	
—	231	299	244.5	206	206	227	234	247	324	324	304	3	3	34.4	33.7	
—	228	—	244	206	—	227	234	247	324	—	—	3	3	39.5	—	
NF	245	345	265	210	210	240	248	268	380	380	351	4	4	49.4	48.3	
—	245	345	265	210	210	240	248	268	380	380	351	4	4	80.5	78.9	
—	229	281	239.4	211	211	226	233	241	299	299	283	2	2	13.9	13.7	
NF	244	316	258	216	216	240	247	261	344	344	321	3	3	25.3	24.8	
—	243	—	259	216	—	240	247	261	344	—	—	3	3	28.1	—	
—	244	316	258	216	216	240	247	261	344	344	321	3	3	41.3	40.5	
—	241	—	257.8	216	—	240	247	261	344	—	—	3	3	47.8	—	
NF	260	360	280	220	220	254	263	283	400	400	366	4	4	55.8	54.5	
—	260	360	280	220	220	254	263	283	400	400	366	4	4	92.6	90.7	
—	250	310	262	233	233	248	254	264	327	327	313	2.5	2.5	18.2	17.9	
NF	270	350	286	236	236	266	273	289	384	384	355	3	3	37.7	37	
—	270	350	286	236	236	266	273	289	384	384	355	3	3	59	57.8	
NF	284	396	307	240	240	279	287	307	440	440	402	4	4	73.4	71.7	
—	284	396	307	240	240	279	287	307	440	440	402	4	4	116	114	

3) Does not apply to the sides of the outer ring rib of type NF bearings.

Cylindrical Roller Bearings

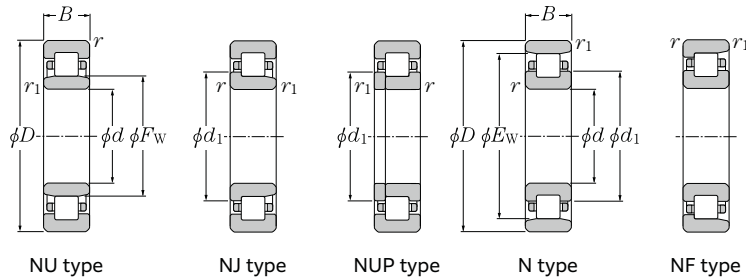

d 240 ~ 440mm

d	Boundary dimensions				Basic load rating		Fatigue load limit kN C _u	Allowable speed ²⁾		Bearing number			
	D	B	r _{s min¹⁾}	r _{1s min¹⁾}	C _r	C _{0r}		Grease lubrication	Oil lubrication	NU type	NJ type	NUP type	N type
240	360	56	3	3	585	820	72.0	1 800	2 100	NU1048	NJ	NUP	N
	440	72	4	4	1 040	1 340	113	1 500	1 700	NU248	NJ	NUP	N
	440	120	4	4	1 590	2 320	196	1 300	1 600	NU2248	NJ	NUP	N
	500	95	5	5	1 590	1 950	160	1 300	1 500	NU348	NJ	NUP	N
	500	155	5	5	2 330	3 200	262	1 100	1 300	NU2348	NJ	NUP	N
260	400	65	4	4	715	1 000	85.0	1 600	1 900	NU1052	NJ	NUP	N
	480	80	5	5	1 270	1 660	137	1 300	1 600	NU252	NJ	NUP	N
	480	130	5	5	1 980	2 930	241	1 200	1 400	NU2252	NJ	NUP	N
	540	102	6	6	1 790	2 230	180	1 200	1 400	NU352	NJ	NUP	N
	540	165	6	6	2 600	3 600	289	1 000	1 200	NU2352	NJ	NUP	N
280	420	65	4	4	730	1 050	88.0	1 500	1 800	NU1056	NJ	NUP	N
	500	80	5	5	1 320	1 760	143	1 200	1 400	NU256	NJ	NUP	N
	500	130	5	5	2 050	3 100	252	1 100	1 300	NU2256	NJ	NUP	N
	580	108	6	6	2 010	2 540	200	1 100	1 200	NU356	NJ	NUP	N
	580	175	6	6	3 000	4 250	335	920	1 100	NU2356	NJ	NUP	N
300	460	74	4	4	950	1 340	109	1 400	1 600	NU1060	NJ	NUP	N
	540	85	5	5	1 560	2 070	164	1 100	1 300	NU260	NJ	NUP	N
	540	140	5	5	2 420	3 650	290	1 000	1 200	NU2260	NJ	NUP	N
320	480	74	4	4	970	1 410	113	1 300	1 500	NU1064	NJ	NUP	N
	580	92	5	5	1 780	2 390	186	1 000	1 200	NU264	NJ	NUP	N
	580	150	5	5	2 830	4 350	340	950	1 100	NU2264	NJ	NUP	N
340	520	82	5	5	1 160	1 670	132	1 200	1 400	NU1068	NJ	NUP	N
360	540	82	5	5	1 190	1 750	136	1 100	1 300	NU1072	NJ	NUP	N
380	560	82	5	5	1 220	1 840	141	1 100	1 200	NU1076	NJ	NUP	N
400	600	90	5	5	1 460	2 190	164	990	1 200	NU1080	NJ	NUP	N
420	620	90	5	5	1 500	2 290	170	950	1 100	NU1084	NJ	NUP	N
440	650	94	6	6	1 590	2 430	178	900	1 100	NU1088	NJ	NUP	N

1) Smallest allowable dimension for chamfer dimension r or r₁.

2) This value is for machined cages; when pressed cages are used, 80% of this value is acceptable.

Cylindrical Roller Bearings

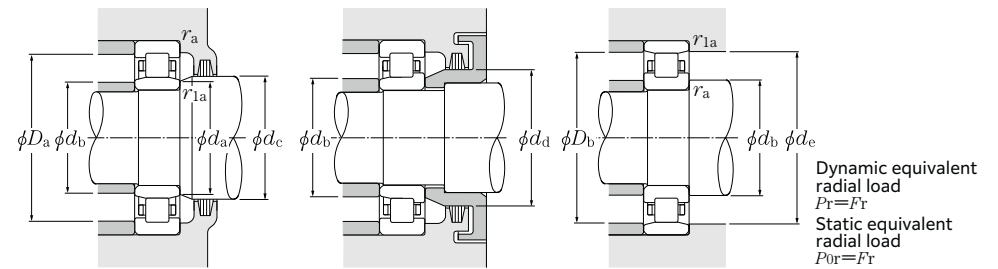

3) Does not apply to the sides of the outer ring rib of type NF bearings.

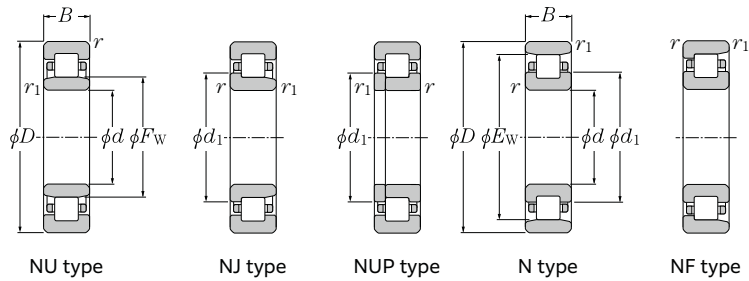

d 460 ~ 500mm

Boundary dimensions					Basic load rating		Fatigue load limit kN C_u	Allowable speed ²⁾		Bearing number			
d	D	B	$r_s \text{ min}^{-1}$	$r_{1s} \text{ min}^{-1}$	dynamic kN C_r	static kN C_{0r}		Grease lubrication	Oil lubrication	NU type	NJ type	NUP type	N type
460	680	100	6	6	1 710	2 630	191	850	1 000	NU1092	NJ	NUP	N
480	700	100	6	6	1 750	2 750	197	810	960	NU1096	NJ	NUP	N
500	720	100	6	6	1 790	2 870	203	770	910	NU10/500	NJ	NUP	N

1) Smallest allowable dimension for chamfer dimension r or r_1 .
2) This value is for machined cages; when pressed cages are used, 80% of this value is acceptable.

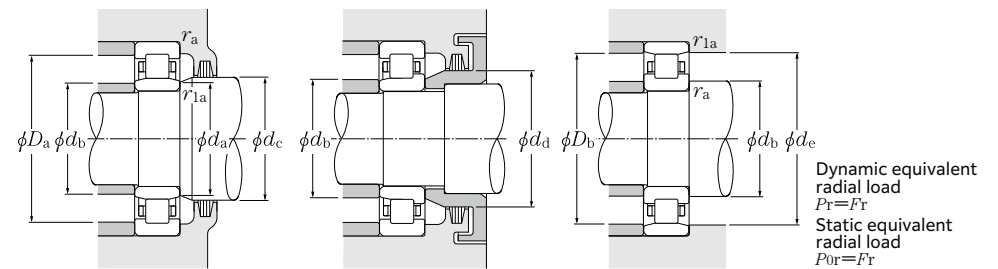

Dynamic equivalent radial load
 $P_r = F_r$
Static equivalent radial load
 $P_{0r} = F_r$

NF type	Dimension				Installation-related dimensions								Mass			
	F_w	E_w	d_1	mm	d_a	d_e	d_b	d_c	d_d	mm	D_a	D_b	r_{as}	r_{1as}	kg	kg
—	516	624	537.6	Min.	484	484	511	522	541	656	656	629	5	5	122	120
—	536	644	557.6	Min.	504	504	531	542	561	676	676	649	5	5	126	124
—	556	664	577.6	Min.	524	524	551	562	581	696	696	669	5	5	130	128

3) Does not apply to the sides of the outer ring rib of type NF bearings.

L type collar ring

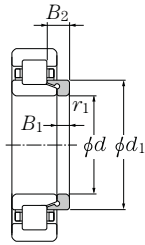

NH=NJ+HJ

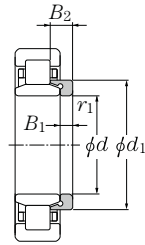

NUJ=NU+HJ

d 20 ~ 60mm

d	Dimension mm				L type collar ring number	Mass kg (approx.)
	d ₁	B ₁	B ₂	r _{1s} min ¹⁾		
20	29.9	3	6.75	0.6	HJ204	0.012
	29.5	3	5.5	0.6	HJ204E	0.009
	29.9	3	7.5	0.6	HJ2204	0.013
	29.5	3	6.5	0.6	HJ2204E	0.01
	31.8	4	7.5	0.6	HJ304	0.017
	31.1	4	6.5	0.6	HJ304E	0.014
	31.8	4	8.5	0.6	HJ2304	0.018
31.1	4	7.5	0.6	HJ2304E	0.015	
25	34.8	3	7.25	0.6	HJ205	0.015
	34.5	3	6	0.6	HJ205E	0.012
	34.8	3	7.5	0.6	HJ2205	0.015
	34.5	3	6.5	0.6	HJ2205E	0.013
	39	4	8	1.1	HJ305	0.025
	38	4	7	1.1	HJ305E	0.021
	39	4	9	1.1	HJ2305	0.027
38	4	8	1.1	HJ2305E	0.024	
43.6	6	10.5	1.5	HJ405	0.057	
30	41.7	4	8.25	0.6	HJ206	0.025
	41.1	4	7	0.6	HJ206E	0.017
	41.7	4	8.5	0.6	HJ2206	0.025
	41.1	4	7.5	0.6	HJ2206E	0.02
	45.9	5	9.5	1.1	HJ306	0.039
	44.9	5	8.5	1.1	HJ306E	0.035
	45.9	5	11.5	1.1	HJ2306	0.043
44.9	5	9.5	1.1	HJ2306E	0.035	
50.5	7	11.5	1.5	HJ406	0.08	
35	47.6	4	8	0.6	HJ207	0.03
	48	4	7	0.6	HJ207E	0.027
	47.6	4	8.5	0.6	HJ2207	0.031
	48	4	8.5	0.6	HJ2207E	0.031
	50.8	6	11	1.1	HJ307	0.056
	51	6	9.5	1.1	HJ307E	0.048
	50.8	6	14	1.1	HJ2307	0.064
51	6	11	1.1	HJ2307E	0.055	
59	8	13	1.5	HJ407	0.12	

d	Dimension mm				L type collar ring number	Mass kg (approx.)
	d ₁	B ₁	B ₂	r _{1s} min ¹⁾		
40	54.2	5	9	1.1	HJ208	0.046
	53.9	5	8.5	1.1	HJ208E	0.042
	54.2	5	9.5	1.1	HJ2208	0.047
	53.9	5	9	1.1	HJ2208E	0.045
	58.4	7	12.5	1.5	HJ308	0.083
	57.6	7	11	1.5	HJ308E	0.07
	58.4	7	14.5	1.5	HJ2308	0.09
57.6	7	12.5	1.5	HJ2308E	0.08	
64.8	8	13	2	HJ408	0.14	
45	59	5	9.5	1.1	*HJ209	0.053
	58.9	5	8.5	1.1	HJ209E	0.047
	58.9	5	9	1.1	HJ2209E	0.05
	64	7	12.5	1.5	HJ309	0.099
	64.5	7	11.5	1.5	HJ309E	0.093
	64	7	15	1.5	HJ2309	0.109
	64.5	7	13	1.5	HJ2309E	0.103
71.8	8	13.5	2	HJ409	0.175	
50	64.6	5	10	1.1	HJ210	0.063
	63.9	5	9	1.1	*HJ210E	0.055
	64.6	5	9.5	1.1	HJ2210	0.061
	71	8	14	2	HJ310	0.142
	71.4	8	13	2	HJ310E	0.134
	71	8	17	2	HJ2310	0.157
	71.4	8	14.5	2	HJ2310E	0.15
78.8	9	14.5	2.1	HJ410	0.23	
55	70.8	6	11	1.1	*HJ211	0.084
	70.8	6	9.5	1.1	HJ211E	0.072
	70.8	6	10	1.1	HJ2211E	0.076
	77.2	9	15	2	HJ311	0.182
	77.7	9	14	2	HJ311E	0.168
	77.2	9	18.5	2	HJ2311	0.203
	77.7	9	15.5	2	HJ2311E	0.185
85.2	10	16.5	2.1	HJ411	0.29	
60	78.4	6	11	1.5	*HJ212	0.108
	77.6	6	10	1.5	*HJ212E	0.094

1) Smallest allowable dimension for chamfer dimension r. Note: 1 This L type collar ring is used with NU type cylindrical roller bearings; in duplex arrangements with NJ or NU type bearing numbers, they become NH type and NUJ type respectively. Refer to pages B-98 to B-101 for bearing dimensions, allowable rotations, and mass. 2. "*" indicates L type collar rings that can also be used with dimension series 22 bearings.

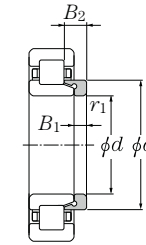

NH=NJ+HJ

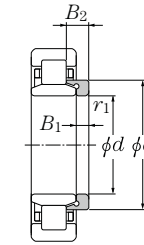

NUJ=NU+HJ

d 60 ~ 105mm

d	Dimension mm				L type collar ring number	Mass kg (approx.)
	d ₁	B ₁	B ₂	r _{1s} min ¹⁾		
60	84.2	9	15.5	2.1	HJ312	0.22
	84.6	9	14.5	2.1	HJ312E	0.205
	84.2	9	19	2.1	HJ2312	0.245
	84.6	9	16	2.1	HJ2312E	0.23
	91.8	10	16.5	2.1	HJ412	0.34
65	84.8	6	11	1.5	HJ213	0.123
	84.5	6	10	1.5	HJ213E	0.111
	84.8	6	11.5	1.5	HJ2213	0.126
	84.5	6	10.5	1.5	HJ2213E	0.118
	91	10	17	2.1	HJ313	0.28
70	91	10	15.5	2.1	HJ313E	0.25
	91	10	20	2.1	HJ2313	0.304
	91	10	18	2.1	HJ2313E	0.29
	98.5	11	18	2.1	HJ413	0.42
	75	89.6	7	12.5	1.5	*HJ214
89.5		7	11	1.5	HJ214E	0.13
89.5		7	11.5	1.5	HJ2214E	0.138
98		10	17.5	2.1	HJ314	0.33
98		10	15.5	2.1	HJ314E	0.293
80	98	10	20.5	2.1	HJ2314	0.358
	98	10	18.5	2.1	HJ2314E	0.35
	110.5	12	20	3	HJ414	0.605
	94	7	12.5	1.5	*HJ215	0.156
	94.5	7	11	1.5	HJ215E	0.141
85	94.5	7	11.5	1.5	HJ2215E	0.164
	104.2	11	18.5	2.1	HJ315	0.4
	104.6	11	16.5	2.1	HJ315E	0.35
	104.2	11	21.5	2.1	HJ2315	0.432
	104.6	11	19.5	2.1	HJ2315E	0.41
90	116	13	21.5	3	HJ415	0.71
	94.5	7	12.5	1.5	*HJ215	0.156
	94.5	7	11	1.5	HJ215E	0.141
	94.5	7	11.5	1.5	HJ2215E	0.164
	104.2	11	18.5	2.1	HJ315	0.4
95	104.6	11	16.5	2.1	HJ315E	0.35
	104.2	11	21.5	2.1	HJ2315	0.432
	104.6	11	19.5	2.1	HJ2315E	0.41
	116	13	21.5	3	HJ415	0.71
	100	101.2	8	13.5	2	*HJ216
101.7		8	12.5	2	*HJ216E	0.193
111.8		11	19.5	2.1	HJ316	0.47
111		11	17	2.1	HJ316E	0.405
111.8		11	23	2.1	HJ2316	0.511

1) Smallest allowable dimension for chamfer dimension r. Note: 1 This L type collar ring is used with NU type cylindrical roller bearings; in duplex arrangements with NJ or NU type bearing numbers, they become NH type and NUJ type respectively. Refer to pages B-102 to B-107 for bearing dimensions, allowable rotations, and mass. 2. "*" indicates L type collar rings that can also be used with dimension series 22 bearings.

L type collar ring

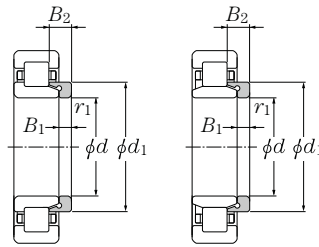

NH=NJ+HJ

NUJ=NU+HJ

d 105 ~ 200mm

d	Dimension mm				r _{1s} min ¹⁾	L type collar ring number	Mass kg (approx.)
	d ₁	B ₁	B ₂				
105	147	13	22.5	3		HJ321	0.97
110	141.5	11	18.5	2.1		HJ222	0.615
	142.1	11	17	2.1		HJ222E	0.553
	141.5	11	20.5	2.1		HJ2222	0.645
	142.1	11	19.5	2.1		HJ2222E	0.605
	155.5	14	23	3		HJ322	1.17
	156.6	14	22	3		HJ322E	1.09
	155.5	14	28	3		HJ2322	1.28
	156.6	14	26.5	3		HJ2322E	1.25
120	153	11	19	2.1		HJ224	0.715
	153.9	11	17	2.1		HJ224E	0.634
	153	11	22	2.1		HJ2224	0.767
	153.9	11	20	2.1		HJ2224E	0.705
	168.5	14	23.5	3		HJ324	1.4
	169.2	14	22.5	3		HJ324E	1.28
	168.5	14	28	3		HJ2324	1.53
	169.2	14	26	3		HJ2324E	1.42
130	165.5	11	19	3		HJ226	0.84
	164.7	11	17	3		HJ226E	0.684
	165.5	11	25	3		HJ2226	0.953
	164.7	11	21	3		HJ2226E	0.831
	182	14	24	4		HJ326	1.62
	183	14	23	4		HJ326E	1.53
	182	14	29.5	4		HJ2326	1.8
	183	14	28	4		HJ2326E	1.75
140	179.5	11	19	3		HJ228	1
	180.2	11	18	3		HJ228E	0.929
	179.5	11	25	3		HJ2228	1.14
	180.2	11	23	3		HJ2228E	1.11
	196	15	26	4		HJ328	1.93
	196.8	15	25	4		HJ328E	1.91
	196	15	33.5	4		HJ2328	2.21
	196.8	15	31	4		HJ2328E	2.3
150	193	12	20.5	3		HJ230	1.24

1) Smallest allowable dimension for chamfer dimension r.

Note: 1 This L type collar ring is used with NU type cylindrical roller bearings; in duplex arrangements with NJ or NU type bearing numbers, they become NH type and NUJ type respectively. Refer to pages B-106 to B-111 for bearing dimensions, allowable rotations, and mass.

d	Dimension mm				r _{1s} min ¹⁾	L type collar ring number	Mass kg (approx.)
	d ₁	B ₁	B ₂				
150	194	12	19.5	3		HJ230E	1.18
	193	12	26.5	3		HJ2230	1.39
	194	12	24.5	3		HJ2230E	1.42
	210	15	26.5	4		HJ330	2.37
	211	15	25	4		HJ330E	2.25
	210	15	34	4		HJ2330	2.69
	211	15	31.5	4		HJ2330E	2.6
160	207	12	21	3		HJ232	1.48
	207.8	12	20	3		HJ232E	1.34
	207	12	28	3		HJ2232	1.69
	206.6	12	24.5	3		HJ2232E	1.61
	225	15	28	4		HJ332	2.75
	223.2	15	25	4		HJ332E	2.4
	225	15	37	4		HJ2332	3.16
	223.2	15	32	4		HJ2332E	2.85
170	220.5	12	22	4		HJ234	1.7
	221.4	12	20	4		HJ234E	1.51
	220.5	12	29	4		HJ2234	1.93
	220.2	12	24	4		HJ2234E	1.82
	238	16	29.5	4		HJ334	3.25
	238	16	38.5	4		HJ2334	3.71
	180	230.5	12	22	4		HJ236
231.4		12	20	4		HJ236E	1.7
230.5		12	29	4		HJ2236	2.04
230.2		12	24	4		HJ2236E	1.91
252		17	30.5	4		HJ336	3.85
252		17	40	4		HJ2336	4.42
190		244.5	13	23.5	4		HJ238
	245.2	13	21.5	4		HJ238E	1.94
	244.5	13	31.5	4		HJ2238	2.52
	244	13	26.5	4		HJ2238E	2.38
	265	18	32	5		HJ338	4.45
	265	18	41.5	5		HJ2338	5.05
	200	258	14	25	4		HJ240

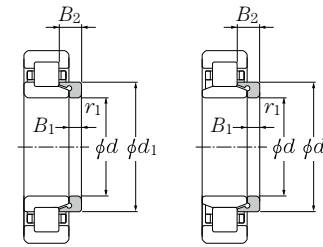

NH=NJ+HJ

NUJ=NU+HJ

d 200 ~ 320mm

d	Dimension mm				r _{1s} min ¹⁾	L type collar ring number	Mass kg (approx.)
	d ₁	B ₁	B ₂				
200	259	14	23	4		HJ240E	2.35
	258	14	34	4		HJ2240	2.99
	257.8	14	28	4		HJ2240E	2.86
	280	18	33	5		HJ340	5
	280	18	44.5	5		HJ2340	5.76
220	286	15	27.5	4		HJ244	3.55
	307	20	36	5		HJ344	7.05
240	313	16	29.5	4		HJ248	4.65
	335	22	39.5	5		HJ348	8.2
260	340	18	33	5		HJ252	6.2
	362	24	43	6		HJ352	11.4
280	360	18	33	5		HJ256	7.39
	390	26	46	6		HJ356	13.9
300	387	20	34.5	5		HJ260	9.14
320	415	21	37	5		HJ264	11.3

1) Smallest allowable dimension for chamfer dimension r.

Note: 1 This L type collar ring is used with NU type cylindrical roller bearings; in duplex arrangements with NJ or NU type bearing numbers, they become NH type and NUJ type respectively. Refer to pages B-110 to B-113 for bearing dimensions, allowable rotations, and mass.

● Double Row Cylindrical Roller Bearings

WBW

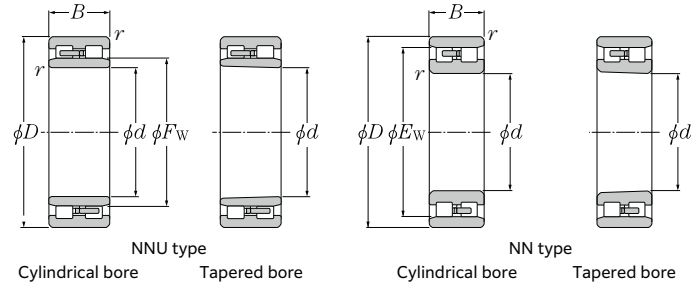

d 25 ~ 110mm

d	Boundary dimensions			Basic load rating		Fatigue load limit kN C_u	Allowable speed		Bearing number ²⁾	
	D	B	$r_{s \min}^{1)}$	dynamic kN C_r	static C_{0r}		min ⁻¹ Grease lubrication	Oil lubrication	NNU type	
									Cylindrical bore	Tapered bore
25	47	16	0.6	28.6	30.0	3.65	14 000	17 000	—	—
30	55	19	1	34.0	37.0	4.55	12 000	15 000	—	—
35	62	20	1	42.0	47.5	5.80	11 000	13 000	—	—
40	68	21	1	48.0	55.5	6.75	9 700	11 000	—	—
45	75	23	1	57.5	68.5	8.35	8 800	10 000	—	—
50	80	23	1	59.0	72.5	8.85	8 000	9 400	—	—
55	90	26	1.1	77.0	96.5	11.8	7 300	8 600	—	—
60	95	26	1.1	78.5	102	12.4	6 700	7 900	—	—
65	100	26	1.1	83.0	111	13.6	6 200	7 300	—	—
70	110	30	1.1	105	143	17.4	5 800	6 800	—	—
75	115	30	1.1	107	149	18.2	5 400	6 300	—	—
80	125	34	1.1	128	179	21.6	5 100	5 900	—	—
85	130	34	1.1	135	194	23.1	4 800	5 600	—	—
90	140	37	1.5	158	228	26.6	4 500	5 300	—	—
95	145	37	1.5	162	238	27.4	4 300	5 000	—	—
100	140	40	1.1	145	260	30.0	4 300	5 100	NNU4920	NNU4920K
	150	37	1.5	170	256	29.2	4 000	4 800	—	—
105	145	40	1.1	147	268	30.5	4 100	4 800	NNU4921	NNU4921K
	160	41	2	220	320	36.0	3 800	4 500	—	—
110	150	40	1.1	152	284	32.0	3 900	4 600	NNU4922	NNU4922K
	170	45	2	254	375	41.5	3 600	4 300	—	—

● Double Row Cylindrical Roller Bearings

WBW

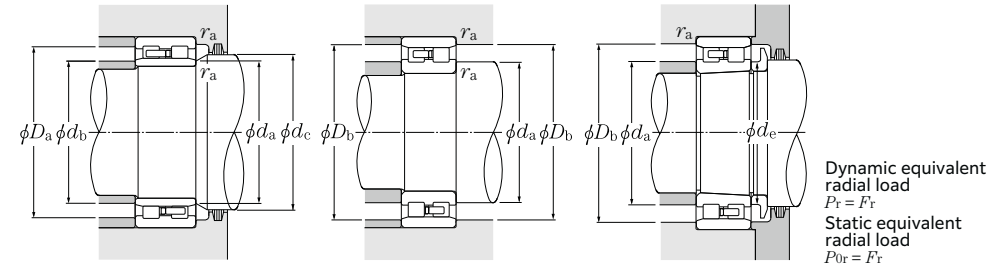

Bearing number ²⁾	Dimension		Installation-related dimensions								Mass (approx.) kg				
	mm F_w	mm E_w	d_a Min.	d_e Min.	d_b Max.	d_c Min.	D_a Max.	D_b Max.	D_b Min.	r_{as} Max.	NNU type		NN type		
											Cylindrical bore	Tapered bore	Cylindrical bore	Tapered bore	
NN3005	NN3005K	—	41.3	29	30	—	—	—	43	42	0.6	—	—	0.124	0.121
NN3006	NN3006K	—	48.5	35	36.5	—	—	—	50	49	1	—	—	0.199	0.193
NN3007	NN3007K	—	55	40	41.5	—	—	—	57	56	1	—	—	0.242	0.235
NN3008	NN3008K	—	61	45	47	—	—	—	63	62	1	—	—	0.312	0.303
NN3009	NN3009K	—	67.5	50	52	—	—	—	70	69	1	—	—	0.405	0.393
NN3010	NN3010K	—	72.5	55	57	—	—	—	75	74	1	—	—	0.433	0.419
NN3011	NN3011K	—	81	61.5	63.5	—	—	—	83.5	82	1	—	—	0.651	0.631
NN3012	NN3012K	—	86.1	66.5	68.5	—	—	—	88.5	87	1	—	—	0.704	0.683
NN3013	NN3013K	—	91	71.5	73.5	—	—	—	93.5	92	1	—	—	0.758	0.735
NN3014	NN3014K	—	100	76.5	79	—	—	—	103.5	101	1	—	—	1.04	1.01
NN3015	NN3015K	—	105	81.5	84	—	—	—	108.5	106	1	—	—	1.14	1.11
NN3016	NN3016K	—	113	86.5	89.5	—	—	—	118.5	114	1	—	—	1.52	1.47
NN3017	NN3017K	—	118	91.5	94.5	—	—	—	123.5	119	1	—	—	1.61	1.56
NN3018	NN3018K	—	127	98	101	—	—	—	132	129	1.5	—	—	2.07	2.01
NN3019	NN3019K	—	132	103	106	—	—	—	137	134	1.5	—	—	2.17	2.1
NN4920	NN4920K	113	129	106.5	110	111	115	133.5	133.5	131	1	1.83	1.75	1.75	1.67
NN3020	NN3020K	—	137	108	111	—	—	—	142	139	1.5	—	—	2.26	2.19
NN4921	NN4921K	118	134	111.5	115	116	120	138.5	138.5	136	1	1.91	1.82	1.82	1.73
NN3021	NN3021K	—	146	114	117	—	—	—	151	148	2	—	—	2.89	2.8
NN4922	NN4922K	123	139	116.5	120	121	125	143.5	143.5	141	1	1.99	1.9	1.9	1.81
NN3022	NN3022K	—	155	119	123	—	—	—	161	157	2	—	—	3.69	3.56

1) Smallest allowable dimension for chamfer dimension r .
 2) "K" indicates bearings having a tapered bore with a taper ratio of 1:12.

Double Row Cylindrical Roller Bearings

WBW

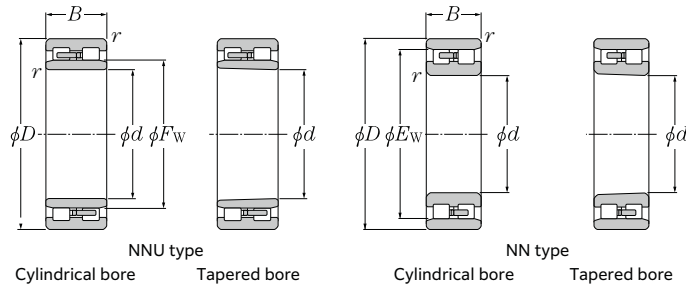

d 120 ~ 280mm

d	Boundary dimensions				Basic load rating		Fatigue load limit kN C _u	Allowable speed		Bearing number ²⁾	
	mm				dynamic kN C _r	static kN C _{0r}		min ⁻¹ Grease lubrication	Oil lubrication	NNU type	
	D	B	r _{s min} ¹⁾	r					Cylindrical bore	Tapered bore	
120	165	45	1.1	203	360	39.5	3 600	4 200	NNU4924	NNU4924K	
	180	46	2	258	390	42.5	3 300	3 900	—	—	
130	180	50	1.5	244	440	47.0	3 300	3 900	NNU4926	NNU4926K	
	200	52	2	315	475	50.0	3 100	3 600	—	—	
140	190	50	1.5	251	470	49.0	3 000	3 600	NNU4928	NNU4928K	
	210	53	2	330	515	53.0	2 800	3 300	—	—	
150	210	60	2	380	690	70.5	2 800	3 300	NNU4930	NNU4930K	
	225	56	2.1	370	585	59.0	2 600	3 100	—	—	
160	220	60	2	395	740	74.0	2 600	3 100	NNU4932	NNU4932K	
	240	60	2.1	415	660	65.5	2 500	2 900	—	—	
170	230	60	2	400	765	75.5	2 500	2 900	NNU4934	NNU4934K	
	260	67	2.1	490	775	75.0	2 300	2 700	—	—	
180	250	69	2	510	965	93.0	2 300	2 700	NNU4936	NNU4936K	
	280	74	2.1	630	995	94.5	2 200	2 600	—	—	
190	260	69	2	525	1 030	98.0	2 200	2 600	NNU4938	NNU4938K	
	290	75	2.1	640	1 040	97.0	2 000	2 400	—	—	
200	280	80	2.1	615	1 180	110	2 100	2 400	NNU4940	NNU4940K	
	310	82	2.1	725	1 170	107	1 900	2 300	—	—	
220	300	80	2.1	650	1 300	118	1 900	2 200	NNU4944	NNU4944K	
	340	90	3	905	1 480	132	1 700	2 100	—	—	
240	320	80	2.1	680	1 410	126	1 700	2 000	NNU4948	NNU4948K	
	360	92	3	945	1 600	140	1 600	1 900	—	—	
260	360	100	2.1	1 000	2 070	179	1 600	1 800	NNU4952	NNU4952K	
	400	104	4	1 180	1 990	170	1 500	1 700	—	—	
280	380	100	2.1	1 030	2 200	187	1 400	1 700	NNU4956	NNU4956K	
	420	106	4	1 200	2 080	174	1 300	1 600	—	—	

1) Smallest allowable dimension for chamfer dimension r.
2) "K" indicates bearings having a tapered bore with a taper ratio of 1:12.

Double Row Cylindrical Roller Bearings

WBW

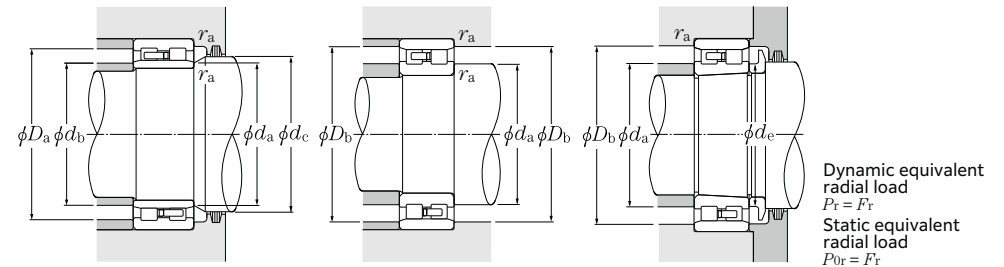

Dynamic equivalent radial load
 $P_r = F_r$
Static equivalent radial load
 $P_{0r} = F_r$

Bearing number ²⁾	Dimension		Installation-related dimensions										Mass (approx.) kg			
	NNU type Cylindrical bore	NN type Tapered bore	F _w	E _w	d _a Min.	d _e Min.	d _b Max.	d _c Min.	D _a Max.	D _b Max.	D _b Min.	r _{as} Max.	NNU type Cylindrical bore	NN type Tapered bore	Cylindrical bore	Tapered bore
NN4924	NN4924K	134.5	154.5	126.5	130	133	137	158.5	158.5	156.5	1	2.75	2.63	2.63	2.51	
		—	165	129	133	—	—	—	171	167	2	—	—	3.98	3.83	
NN4926	NN4926K	146	168	138	142	144	148	172	172	170	1.5	3.69	3.52	3.52	3.35	
		—	182	139	143	—	—	—	191	183	2	—	—	5.92	5.71	
NN4928	NN4928K	156	178	148	152	154	158	182	182	180	1.5	3.94	3.76	3.76	3.58	
		—	192	149	153	—	—	—	201	194	2	—	—	6.44	6.21	
NN4930	NN4930K	168.5	196.5	159	164	166	171	201	201	198.5	2	6.18	5.9	5.9	5.62	
		—	206	161	166	—	—	—	214	208	2	—	—	7.81	7.53	
NN4932	NN4932K	178.5	206.5	169	174	176	182	211	211	208.5	2	6.53	6.23	6.24	5.94	
		—	219	171	176	—	—	—	229	221	2	—	—	8.92	8.59	
NN4934	NN4934K	188.5	216.5	179	184	186	192	221	221	218.5	2	6.87	6.55	6.56	6.24	
		—	236	181	187	—	—	—	249	238	2	—	—	12.6	12.2	
NN4936	NN4936K	202	234	189	195	199	205	241	241	236	2	9.9	9.46	9.45	9.01	
		—	255	191	197	—	—	—	269	257	2	—	—	16.6	16	
NN4938	NN4938K	212	244	199	205	209	215	251	251	246	2	10.4	9.94	9.93	9.47	
		—	265	201	207	—	—	—	279	267	2	—	—	18	17.4	
NN4940	NN4940K	225	261	211	218	222	228	269	269	264	2	14.7	14	14	13.3	
		—	282	211	218	—	—	—	299	285	2	—	—	21.6	20.8	
NN4944	NN4944K	245	281	231	238	242	248	289	289	284	2	15.9	15.2	15.2	14.5	
		—	310	233	240	—	—	—	327	313	2.5	—	—	29.3	28.2	
NN4948	NN4948K	265	301	251	258	262	269	309	309	304	2	17.2	16.4	16.4	15.6	
		—	330	253	261	—	—	—	347	333	2.5	—	—	32.8	31.6	
NN4952	NN4952K	292	336	271	279	288	296	349	349	339	2	29.6	28.3	28.3	27	
		—	364	276	285	—	—	—	384	367	3	—	—	47.4	45.8	
NN4956	NN4956K	312	356	291	299	308	316	369	369	359	2	31.6	30.2	30.2	28.8	
		—	384	296	305	—	—	—	404	387	3	—	—	51.1	49.3	

Double Row Cylindrical Roller Bearings

WBW

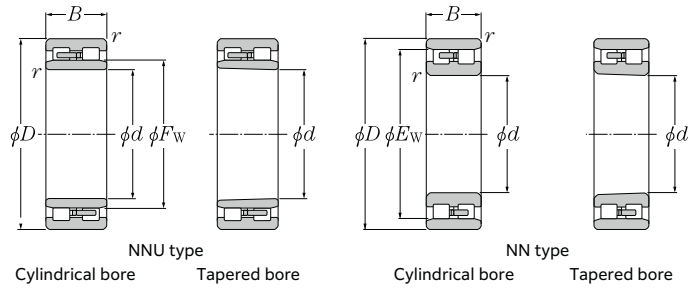

d 300 ~ 500mm

<i>d</i>	Boundary dimensions			Basic load rating		Fatigue load limit kN C_{10}	Allowable speed		Bearing number ²⁾	
	<i>D</i>	<i>B</i>	r_s min ¹⁾	dynamic kN C_R	static kN C_{0R}		min ⁻¹ Grease lubrication	Oil lubrication	NNU type	
	mm								Cylindrical bore	Tapered bore
300	420	118	3	1 330	2 800	231	1 300	1 500	NNU4960	NNU4960K
	460	118	4	1 470	2 560	209	1 200	1 500	—	—
320	440	118	3	1 370	2 970	242	1 200	1 400	NNU4964	NNU4964K
	480	121	4	1 500	2 670	214	1 100	1 300	—	—
340	460	118	3	1 410	3 150	252	1 100	1 300	NNU4968	NNU4968K
	520	133	5	1 800	3 200	251	1 100	1 300	—	—
360	480	118	3	1 430	3 250	255	1 100	1 300	NNU4972	NNU4972K
	540	134	5	1 830	3 300	258	1 000	1 200	—	—
380	520	140	4	1 810	4 050	315	1 000	1 200	NNU4976	NNU4976K
	560	135	5	1 870	3 450	265	940	1 100	—	—
400	540	140	4	1 870	4 300	325	940	1 100	NNU4980	NNU4980K
	600	148	5	2 260	4 150	310	880	1 000	—	—
420	560	140	4	1 930	4 500	340	900	1 100	NNU4984	NNU4984K
	620	150	5	2 300	4 300	320	840	990	—	—
440	600	160	4	2 380	5 550	410	850	1 000	NNU4988	NNU4988K
	650	157	6	2 680	5 100	370	800	940	—	—
460	620	160	4	2 460	5 850	430	800	950	NNU4992	NNU4992K
	680	163	6	2 830	5 350	385	750	890	—	—
480	650	170	5	2 530	5 900	425	770	910	NNU4996	NNU4996K
500	670	170	5	2 670	6 400	455	730	860	NNU49/500	NNU49/500K

Double Row Cylindrical Roller Bearings

WBW

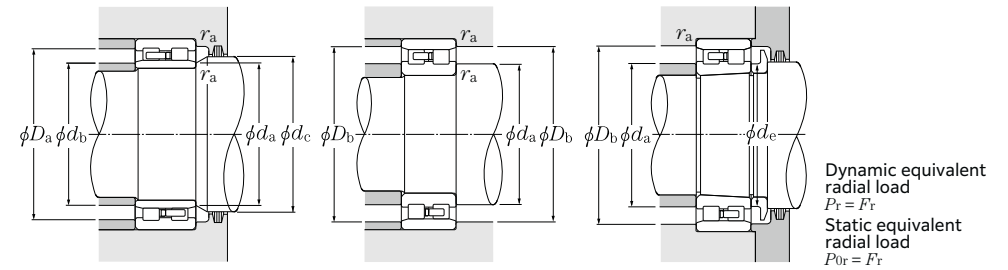

Dynamic equivalent radial load
 $P_r = F_r$
Static equivalent radial load
 $P_{0r} = F_r$

Bearing number ²⁾	Dimension		Installation-related dimensions										Mass (approx.) kg							
	Cylindrical bore	Tapered bore	mm		d_a		d_e		d_b		d_c		D_a		D_b		r_{as}		NNU type	
			F_w	E_w	Min.	Max.	Min.	Max.	Min.	Max.	Min.	Max.	Min.	Max.	Min.	Max.	Cylindrical bore	Tapered bore	Cylindrical bore	Tapered bore
NN4960	NN4960K	339	391	313	323	335	343	407	407	394	2.5	48.6	46.4	46.4	44.2					
NN3060	NN3060K	—	418	316	326	—	—	—	444	421	3	—	—	70.8	68.6					
NN4964	NN4964K	359	411	333	343	355	363	427	427	414	2.5	51.4	49.1	49	46.7					
NN3064	NN3064K	—	438	336	346	—	—	—	464	441	3	—	—	76.2	73.5					
—	—	379	—	353	363	375	383	447	—	—	2.5	54.2	51.7	—	—					
NN3068	NN3068K	—	473	360	371	—	—	—	500	477	4	—	—	102	98.5					
—	—	398	—	373	383	394	402	467	—	—	2.5	57	54.4	—	—					
NN3072	NN3072K	—	493	380	391	—	—	—	520	497	4	—	—	107	103					
—	—	425	—	396	408	420	430	504	—	—	3	84.5	80.6	—	—					
NN3076	NN3076K	—	512	400	411	—	—	—	540	516	4	—	—	113	109					
—	—	445	—	416	428	440	450	524	—	—	3	88.2	84.1	—	—					
NN3080	NN3080K	—	547	420	432	—	—	—	580	551	4	—	—	146	141					
—	—	465	—	436	448	460	470	544	—	—	3	92	87.7	—	—					
NN3084	NN3084K	—	567	440	452	—	—	—	600	571	4	—	—	154	148					
—	—	492	—	456	469	487	497	584	—	—	3	127	121	—	—					
NN3088	NN3088K	—	596	464	477	—	—	—	626	601	5	—	—	178	172					
—	—	512	—	476	489	507	517	604	—	—	3	132	126	—	—					
NN3092	NN3092K	—	622	484	498	—	—	—	656	627	5	—	—	202	195					
—	—	534	—	500	514	531	541	630	—	—	4	156	149	—	—					
—	—	556	—	520	534	551	561	650	—	—	4	162	155	—	—					

1) Smallest allowable dimension for chamfer dimension *r*.
2) "K" indicates bearings having a tapered bore with a taper ratio of 1:12.
B-124